

# LATTICES WITH LARGE MINIMAL EXTENSIONS

RALPH FREESE, JAROSLAV JEŽEK, AND J. B. NATION

ABSTRACT. This paper characterizes those finite lattices which are a maximal sublattice of an infinite lattice. There are 145 minimal lattices with this property, and a finite lattice has an infinite minimal extension if and only if it contains one of these 145 as a sublattice.

In [12], I. Rival showed that if  $\mathbf{L}$  is a maximal sublattice of a distributive lattice  $\mathbf{K}$  with  $|\mathbf{K}| > 2$ , then  $|\mathbf{K}| \leq (3/2)|\mathbf{L}|$ . In [1] the authors took up the question for more general varieties. In particular a 14 element lattice was constructed which is a maximal sublattice of an infinite lattice. The question of how small such a lattice could be was raised.

In this paper we will use the term *big lattice* to mean a finite lattice which is a maximal sublattice in an infinite lattice, and *small lattice* for a finite lattice which is not big. Our main result provides an algorithm for determining whether a given finite lattice is big. This allows us to give many interesting examples of both big and small lattices. We will show that  $\mathbf{M}_3$  is big but no smaller lattice is, answering the question mentioned above. On the other hand,  $\mathbf{N}_5$  is small.

Using this algorithm, we produce a complete list of all 145 minimal big lattices. The minimal big lattices (up to dual isomorphism) are denoted by  $\mathbf{G}_i$  for  $1 \leq i \leq 81$ , and are drawn in the figures in Sections 13–18. A finite lattice is big if and only if it contains some  $\mathbf{G}_i$  or  $\mathbf{G}_i^d$  as a sublattice.

## 1. THE PLAN

The outline of the paper, after the preliminaries, goes as follows. Section 3 proves that a superlattice of a big lattice is big. Section 4 proves that a linear sum of small lattices is small. Section 5 gives some examples of small lattices.

Section 6 gives the main construction which will be used to show that a lattice is big. This construction involves gluing a finitely presented lattice  $\mathbf{FQ}(x, y)$  to a finite lattice  $\mathbf{L}$ , where  $\mathbf{Q}(x, y)$  is a partial lattice depending on  $\mathbf{L}$ . If  $\mathbf{FQ}(x, y)$  is infinite, then  $\mathbf{L}$  will be big. There are eight minimal big lattices which require different *ad hoc* constructions of an infinite minimal extension:  $\mathbf{G}_5$ ,  $\mathbf{G}_6$ ,  $\mathbf{G}_6^d$ ,  $\mathbf{G}_7$ ,  $\mathbf{G}_9$ ,  $\mathbf{G}_9^d$ ,  $\mathbf{G}_{13}$  and  $\mathbf{G}_{13}^d$ .

Sections 7 and 8 prove the following result.

**Theorem 1.** *A finite lattice  $\mathbf{L}$  is big if and only if*

---

*Date:* September 12, 1998.

This research was partially supported by NSF grants DMS-9500752 and DMS-9400511, and Grant Agency of the Czech Republic grant 201/96/0312.

1.  $\mathbf{L}$  contains a sublattice isomorphic to some minimal big lattice  $\mathbf{G}_i$  or  $\mathbf{G}_i^d$  with  $1 \leq i \leq 19$ , or
2.  $\mathbf{L}$  contains a sublattice  $\mathbf{K}$  which is semidistributive, breadth 2, and big.

Sections 9 and 10 prove the following result.

**Theorem 2.** *If  $\mathbf{L}$  is a finite, semidistributive, breadth 2, big lattice, then there exist elements  $p, k \in L$  such that  $\mathbf{FQ}(p, k)$  is infinite.*

Since it is possible to decide whether a finitely presented lattice is infinite, this gives us an algorithm for determining whether a finite lattice is big or small, which is given in Section 11. In Section 12, we prove that every small lattice has a largest minimal extension, which is formed by gluing  $\mathbf{FQ}(p, k)$  to  $\mathbf{L}$  for an appropriate choice of  $p, k \in L$ . Sections 13–18 refine the original algorithm with a characterization of smallness by excluded sublattices.

**Theorem 3.** *Let  $\mathbf{L}$  be a finite, semidistributive, breadth 2 lattice and let  $p, k$  be incomparable elements of  $\mathbf{L}$ . Let  $\mathbf{S}$  be the sublattice  $(p \vee k)/p \cup k/(p \wedge k)$  of  $\mathbf{L}$ .*

1. *If  $\mathbf{S}$  satisfies conditions 1–4 of Theorem 60, then  $\mathbf{FQ}(p, k)$  is finite.*
2. *If  $\mathbf{S}$  fails conditions 1–4 of Theorem 60, then  $\mathbf{FQ}(p, k)$  is infinite, and  $\mathbf{L}$  contains some minimal big lattice  $\mathbf{G}_i$  or  $\mathbf{G}_i^d$  with  $20 \leq i \leq 81$ .*

Thus a finite lattice is big if and only if it contains some  $\mathbf{G}_i$  or  $\mathbf{G}_i^d$  with  $1 \leq i \leq 81$  as a sublattice, and our list of minimal big lattices is complete.

We conclude with some observations about big algebras in other varieties. An example of a lattice which is big in the variety of modular lattices is given.

Computer algorithms play a major role in these results, in two distinct ways. First of all, we need to decide when certain finitely presented lattices are infinite. An algorithm for deciding this was given by V. Slavík in [13, 14], but it is not particularly efficient. For a lattice freely generated by a join trivial (or meet trivial) partial lattice, we could apply the algorithm of Ježek and Slavík [6]. In the general case, we found that the following method worked well. There is a practical algorithm for determining whether a join irreducible element in a finitely presented lattice is completely join irreducible, due to Freese [4]. Clearly, if a lattice contains a join irreducible element which is not completely join irreducible, then it must be infinite. Moreover, Freese had already coded his algorithm. So, given a finitely presented lattice which we suspected of being infinite, it was a simple matter to look for such an element.

This raises a natural question: Does every infinite finitely presented lattice contain either a join irreducible element which is not completely join irreducible, or a meet irreducible element which is not completely meet irreducible? If, in addition, we could find bounds on the complexity of such an element, then we would have a truly efficient algorithm for deciding the finiteness of a finitely presented lattice.

Secondly, we needed to check that the lattices in our list of minimal big lattices really were minimal, that none of them could be embedded in

another. This is straightforward to program, and the program is clearly more reliable than checking minimality by hand.

## 2. PRELIMINARIES

We write  $\mathbf{L} \leq \mathbf{K}$  to mean that  $\mathbf{L}$  is isomorphic to a sublattice of  $\mathbf{K}$ . In practice, we actually suppress the embedding and regard  $\mathbf{L}$  as a fixed sublattice of  $\mathbf{K}$ . We write  $\mathbf{L} \prec \mathbf{K}$  to mean that  $\mathbf{L}$  is isomorphic to a maximal sublattice of  $\mathbf{K}$ .

If  $\mathbf{L}$  is a finite lattice which is a sublattice of a lattice  $\mathbf{K}$ , then for each  $w \in K$  with  $w \leq 1_{\mathbf{L}}$ , define

$$w^{[\mathbf{L}]} = \bigwedge \{a \in L : a \geq w\}.$$

Note that  $(u \vee v)^{[\mathbf{L}]} = u^{[\mathbf{L}]} \vee v^{[\mathbf{L}]}$  and  $(u \wedge v)^{[\mathbf{L}]} \leq u^{[\mathbf{L}]} \wedge v^{[\mathbf{L}]}$ . Of course  $w \leq w^{[\mathbf{L}]}$ , and  $w^{[\mathbf{L}]} = w$  if and only if  $w \in L$ . Similarly, for each  $w \in K$  with  $w \geq 0_{\mathbf{L}}$ , let

$$w_{[\mathbf{L}]} = \bigvee \{b \in L : b \leq w\}.$$

Then  $(u \wedge v)_{[\mathbf{L}]} = u_{[\mathbf{L}]} \wedge v_{[\mathbf{L}]}$  and  $(u \vee v)_{[\mathbf{L}]} \geq u_{[\mathbf{L}]} \vee v_{[\mathbf{L}]}$ , and  $w_{[\mathbf{L}]} \leq w$ , and  $w_{[\mathbf{L}]} = w$  if and only if  $w \in L$ .

Recall that a lattice is *join semidistributive* if it satisfies

$$\text{SD}_{\vee} \quad a \vee b = a \vee c \quad \text{implies} \quad a \vee b = a \vee (b \wedge c).$$

*Meet semidistributivity* is defined dually and denoted  $\text{SD}_{\wedge}$ . A lattice is *semidistributive* if it satisfies both of these conditions.

We need to recall some basic facts about join semidistributive lattices. The condition  $\text{SD}_{\vee}$  is equivalent to

$$w = \bigvee_i a_i = \bigvee_j b_j \quad \text{implies} \quad w = \bigvee_{i,j} a_i \wedge b_j$$

for finite families  $a_i, b_j$ . Every element  $a$  of a finite join semidistributive lattice  $\mathbf{L}$  has a join representation  $a = \bigvee C$  which is *canonical*, in the sense that if  $a = \bigvee D$  then  $C$  refines  $D$  (i.e., for every  $c \in C$  there exists  $d \in D$  with  $c \leq d$ ). The canonical joinands of the largest element  $1_{\mathbf{L}}$  are join prime. If an element  $p$  is join prime in a finite lattice  $\mathbf{L}$ , then there is a (unique) largest element  $x$  such that  $p \not\leq x$ . We denote this element by  $\kappa(p)$ , and note that  $L$  is the disjoint union,  $L = 1/p \cup \kappa(p)/0$ . (This agrees with the more general definition of  $\kappa(p)$  for a join irreducible element in a meet semidistributive lattice.)

For a join irreducible element  $x$  in a finite lattice, let  $x_*$  denote the unique lower cover of  $x$ . Dually, if  $y$  is meet irreducible, then  $y^*$  denotes its unique upper cover.

Throughout we use  $\mathbf{L}^d$  to denote the dual of  $\mathbf{L}$ .

## 3. EXTENSIONS OF BIG LATTICES

In this section we show that if  $\mathbf{A}$  is a sublattice of  $\mathbf{L}$  and  $\mathbf{A}$  is big then  $\mathbf{L}$  is also. In proving this we make use of the Dedekind-Mac Neille completion, which we quickly review. The details can be found in [2] and [3].

If  $S \subseteq P$ , we let  $S^u$  and  $S^\ell$  denote the sets of upper and lower bounds of  $S$ , i.e.,

$$S^u = \{x \in P : x \geq s \text{ for all } s \in S\}$$

$$S^\ell = \{x \in P : x \leq s \text{ for all } s \in S\}$$

Then  $S \rightarrow S^{u\ell}$  is a closure operator. The closed sets are called *normal ideals*. They are hereditary and closed under arbitrary joins. One easily checks that  $S^{lu\ell} = S^\ell$ , and thus the normal ideals are the sets of the form  $S^\ell$ . *Normal filters* are defined dually and the maps  $S \rightarrow S^u$  and  $S \rightarrow S^\ell$  form a Galois connection between the normal ideals and the normal filters. Because this is a closure system, the set of normal ideals forms a complete lattice under set inclusion known as the *normal* or *Dedekind-Mac Neille completion*. Moreover, the map  $x \mapsto x/0$  strongly embeds  $\mathbf{P}$  in this completion. This means that this map is one-to-one, preserves the order relation and its negation, and also preserves arbitrary joins and meets which exist in  $\mathbf{P}$ . A normal ideal is called finitely generated if it has the form  $S^{u\ell}$  for some finite  $S$ .

Now suppose that  $\mathbf{A}$  is a finite lattice which is a maximal sublattice of an infinite lattice  $\mathbf{K}$ . Note  $0_{\mathbf{A}} = 0_{\mathbf{K}}$  and  $1_{\mathbf{A}} = 1_{\mathbf{K}}$ . We also assume that  $\mathbf{A}$  is a sublattice of a finite lattice  $\mathbf{L}$ . In addition we assume  $0_{\mathbf{A}} = 0_{\mathbf{L}}$  and  $1_{\mathbf{A}} = 1_{\mathbf{L}}$ , but we will remove this assumption later. We assume  $L \cap K = A$ .

Let  $P = L \cup K$  be ordered by the transitive closure of the union of the order relations of  $\mathbf{L}$  and  $\mathbf{K}$ . It is easy to see that this union is acyclic and thus the transitive closure makes  $P$  into an ordered set  $\mathbf{P}$ . Since  $A$  is finite and  $1_{\mathbf{P}} \in A$ , for each element  $x \in P$  there is a least element  $x^{[\mathbf{A}]} \in A$  with  $x \leq x^{[\mathbf{A}]}$ . Of course  $x_{[\mathbf{A}]}$  is defined dually. Note that if  $x \in L$  and  $y \in K$  then  $x \leq_{\mathbf{P}} y$  if and only if  $x^{[\mathbf{A}]} \leq_{\mathbf{K}} y$  if and only if  $x \leq_{\mathbf{L}} y_{[\mathbf{A}]}$ . Moreover, if  $x, y \in L$ , then  $x \vee_{\mathbf{L}} y$  is the join of  $x$  and  $y$  in  $\mathbf{P}$ , and dually. The same holds for  $K$ . The next lemma follows easily from these facts.

**Lemma 4.** *If  $b \in L$ ,  $c \in K$ , and  $x \geq b, c$  in  $\mathbf{P}$ , then*

$$x \geq b^{[\mathbf{A}]} \vee c \quad \text{if } x \in K$$

$$x \geq b \vee c^{[\mathbf{A}]} \quad \text{if } x \in L.$$

*Consequently,  $\{b, c\}^u = \{x \in P : x \geq b^{[\mathbf{A}]} \vee c \text{ or } x \geq b \vee c^{[\mathbf{A}]}\}$ .*

Now we want to consider finitely generated normal ideals and show that they form a sublattice of the Dedekind-Mac Neille completion of  $\mathbf{P}$ . First note that if  $S$  is a finite subset of  $P$  then the normal closure of  $S$  is normal closure of  $\{b, c\}$ , where  $b = \bigvee(S \cap L)$  and  $c = \bigvee(S \cap K)$ .

**Corollary 5.** *The set of all finitely generated normal ideals of  $\mathbf{P}$  is a sublattice  $\mathbf{Q}$  of the Dedekind-Mac Neille completion of  $\mathbf{P}$ .*

*Proof.* The join of two finitely generated normal ideals is finitely generated (for arbitrary  $\mathbf{P}$ ). Let  $S$  and  $T$  be finite subsets of  $P$ . Now the Galois connection between the normal ideals and normal filters implies  $S^{ul} \cap T^{ul} = (S^u \cup T^u)^\ell$ . Hence

$$S^{ul} \cap T^{ul} = (S^{ul} \cap T^{ul})^{ul} = (S^u \cup T^u)^{\ell ul} = (S^u \cup T^u)^\ell.$$

By the lemma and the remarks above,  $S^u$  and  $T^u$ , and hence  $S^u \cup T^u$ , are finitely generated normal filters and so by the dual of the lemma  $(S^u \cup T^u)^\ell$  is a finitely generated normal ideal. Since  $S^{ul} \wedge T^{ul} = S^{ul} \cap T^{ul}$ , this proves the corollary.  $\square$

Notice that the lattice  $\mathbf{Q}$  of this corollary naturally contains  $\mathbf{L}$  and  $\mathbf{K}$  as sublattices and that it is generated by  $L \cup K$ .

**Lemma 6.**  *$\mathbf{L}$  is a maximal sublattice of  $\mathbf{Q}$ .*

*Proof.* Let  $I$  be an element of  $Q$  not in  $L$ . As we pointed out earlier, there exist  $b \in L$  and  $c \in K$  such that  $I$  is the normal ideal generated by  $\{b, c\}$ . Now the join of  $I$  and  $b^{[\mathbf{A}]}$  is the normal ideal generated by  $\{b^{[\mathbf{A}]}, b, c\}$ , i.e.,  $\{b^{[\mathbf{A}]}, c\}^{ul}$ . Since  $b^{[\mathbf{A}]} \vee c^{[\mathbf{A}]} \geq b^{[\mathbf{A}]} \vee c$ , Lemma 4 implies  $\{b^{[\mathbf{A}]}, c\}^u$  is the principal filter  $1/(b^{[\mathbf{A}]} \vee c)$  and so  $\{b^{[\mathbf{A}]}, c\}^{ul}$  is the principal ideal  $(b^{[\mathbf{A}]} \vee c)/0$ . Of course  $b^{[\mathbf{A}]} \vee c \in K$ , but  $b^{[\mathbf{A}]} \vee c \notin A$ . For otherwise we would have  $b \vee c^{[\mathbf{A}]} \leq b^{[\mathbf{A}]} \vee c$ , whence by the lemma  $\{b, c\}^u = 1/(b \vee c^{[\mathbf{A}]})$  and  $I = \{b, c\}^{ul} = (b \vee c^{[\mathbf{A}]})/0 \in L$ , a contradiction.

This shows that the sublattice  $\mathbf{N}$  generated by  $\mathbf{L}$  and  $I$  contains an element of  $K - A$ . Since  $A \subseteq L$  and  $\mathbf{A}$  is a maximal sublattice of  $\mathbf{K}$ ,  $N$  must contain all of  $K$ . But since  $\mathbf{Q}$  is generated by  $L \cup K$ , this shows  $N = Q$ , as desired.  $\square$

**Theorem 7.** *If a finite lattice  $\mathbf{L}$  has a big sublattice, it is also big.*

*Proof.* Let  $\mathbf{A}$  be a big sublattice of  $\mathbf{L}$ . Since  $\mathbf{A}$  is big it is a maximal sublattice of an infinite lattice  $\mathbf{K}$ . If the least and greatest elements of  $\mathbf{A}$  are the same as those of  $\mathbf{L}$ , the result follows from Lemma 6.

Note that the disjoint linear sum  $\mathbf{A} \dot{+} \mathbf{1}$  is a maximal sublattice of  $\mathbf{K} \dot{+} \mathbf{1}$  and so big. Thus, for example, if  $0_{\mathbf{A}} = 0_{\mathbf{L}}$  but  $1_{\mathbf{A}} < 1_{\mathbf{L}}$ , we can use the arguments as above with  $\mathbf{A}$  replaced by  $\mathbf{A} \dot{+} \mathbf{1}$ , and similarly for the other cases.  $\square$

#### 4. LINEAR SUMS OF SMALL LATTICES

If  $\mathbf{L}_0$  and  $\mathbf{L}_1$  are lattices such that  $\mathbf{L}_0$  has a greatest element  $1_{\mathbf{L}_0}$  and  $\mathbf{L}_1$  has a least element  $0_{\mathbf{L}_1}$ , then the (*tight*) linear sum  $\mathbf{L}_0 + \mathbf{L}_1$  is the lattice whose universe is  $L_0 \cup L_1$  with  $0_{\mathbf{L}_1}$  and  $1_{\mathbf{L}_0}$  identified. The order on  $\mathbf{L}_0 + \mathbf{L}_1$  is given by  $x \leq y$  if  $x, y \in L_i$  and  $x \leq y$  in  $\mathbf{L}_i$  ( $i = 0$  or  $1$ ), and  $x \leq y$

whenever  $x \in L_0$  and  $y \in L_1$ . A lattice  $\mathbf{L}$  is *linearly decomposable* if there exists  $m \in L$  such that  $L = m/0 \cup 1/m$ , so that  $\mathbf{L}$  is isomorphic to the linear sum  $m/0 + 1/m$ . A lattice  $\mathbf{L}$  is *linearly indecomposable* if no such element  $m$  exists.

The following result allows us to reduce our search for minimal big lattices to linearly indecomposable lattices.

**Theorem 8.** *If  $\mathbf{L}_0$  and  $\mathbf{L}_1$  are small lattices, then the linear sum  $\mathbf{L}_0 + \mathbf{L}_1$  is also small.*

*Proof.* Assume  $\mathbf{L} = \mathbf{L}_0 + \mathbf{L}_1 \prec \mathbf{K}$ , where  $\mathbf{L}_0$  and  $\mathbf{L}_1$  are both small. If there exists  $p \in K - L$  with  $p_{[\mathbf{L}]} \in L_1$  or  $p^{[\mathbf{L}]} \in L_0$ , then  $\mathbf{K} = \text{Sg}(L \cup \{p\})$  is finite because  $\mathbf{L}_0$  and  $\mathbf{L}_1$  are small. Thus we may assume that for all  $p \in K - L$  we have  $p^{[\mathbf{L}]} \in L_1 - \{0_{\mathbf{L}_1}\}$  and  $p_{[\mathbf{L}]} \in L_0 - \{1_{\mathbf{L}_0}\}$ . Choose  $p \in K - L$  such that  $p^{[\mathbf{L}]} / p_{[\mathbf{L}]}$  has minimal length in  $\mathbf{L}$ . If  $x \in \mathbf{L}_0$  and  $x \not\leq p_{[\mathbf{L}]}$ , then  $p \vee x \in L$  because  $(p \vee x)^{[\mathbf{L}]} = p^{[\mathbf{L}]} \vee x = p^{[\mathbf{L}]}$  and  $(p \vee x)_{[\mathbf{L}]} \geq p_{[\mathbf{L}]} \vee x > p_{[\mathbf{L}]}$ ; thus in fact  $p \vee x = p^{[\mathbf{L}]}$ . It follows then that for any  $u \in L$ ,

$$p \vee u = \begin{cases} p & \text{if } u \leq p_{[\mathbf{L}]}, \\ p^{[\mathbf{L}]} \vee u & \text{if } u \not\leq p_{[\mathbf{L}]} \end{cases}$$

Dually,  $p \wedge u \in L$  for all  $u \in L$ . Thus  $L \cup \{p\}$  is a sublattice of  $K$ , whence  $L \cup \{p\} = K$ , and  $\mathbf{K}$  is finite.  $\square$

## 5. SMALL LATTICES

In this section we give some examples of lattices that have a finite bound on the size of their minimal extensions. We begin with an obvious but useful lemma.

**Lemma 9.** *Let  $S$  be a set of intervals of a lattice  $\mathbf{L}$  such that if  $a/b$  and  $c/d$  are in  $S$  then each of  $a \vee c / b \vee d$  and  $a \wedge c / b \wedge d$  is a subinterval of some member of  $S$ . Then the union of these intervals is a sublattice of  $\mathbf{L}$ .*

**The lattice  $\mathbf{D}_1$ .** Let  $\mathbf{D}_1$  be the lattice diagrammed and labelled in Figure 1.

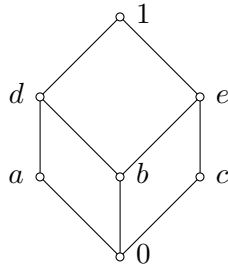

FIGURE 1.  $\mathbf{D}_1$

**Theorem 10.** *If  $\mathbf{D}_1$  is a maximal sublattice of a lattice  $\mathbf{L}$ , then  $|\mathbf{L}| \leq 15$ .*

Strictly speaking, this result is superfluous, for it follows from the more general case considered in the proof of Theorem 31. However, the argument is instructive.

As we prove various parts of the theorem, we will be able to make progressively stronger assumptions. To begin with, assume that

- (1)  $\mathbf{L}$  is a lattice containing  $\mathbf{D}_1$  as a sublattice.

**Lemma 11.**  $D_1 \cup d/a \cup b/0 \cup e/c$  is a sublattice of  $\mathbf{L}$ .

*Proof.* This follows from Lemma 9 by letting  $S$  be the four intervals  $d/a$ ,  $b/0$ ,  $e/c$ , and  $1/1$ .  $\square$

Now we make the stronger assumption that

- (2)  $\mathbf{D}_1$  is a maximal sublattice of  $\mathbf{L}$ .

Notice this implies that the sublattice generated by  $D_1$  and any  $x \notin D_1$  is  $\mathbf{L}$ .

**Lemma 12.** If  $x \in b/0$  then  $1/x \cup \{0, a, c\}$  is a sublattice of  $\mathbf{L}$ .

*Proof.* Clearly this set is closed under joins. Suppose  $y \geq x$  in  $\mathbf{L}$ . By the previous lemma and our stronger assumption,  $L = D_1 \cup d/a \cup b/0 \cup e/c$ . If  $y \in e/c$  then  $a \wedge y = 0$  since  $a \wedge e = 0$ . All other cases are either symmetric or easier.  $\square$

**Corollary 13.** The interval  $b/0$  in  $\mathbf{L}$  has at most 3 elements.

*Proof.* If  $0 < x, y < b$  then Lemma 12 implies both  $x \leq y$  and  $y \leq x$ .  $\square$

**Lemma 14.** If  $0 < x < b$  in  $\mathbf{L}$ , then  $\mathbf{L}$  is isomorphic to one of the lattices in Figure 2.

*Proof.* If  $x \vee a = d$  and  $x \vee c = e$  then  $\mathbf{L}$  is the lattice on the left in Figure 2. If  $x \vee a < d$  then  $(x \vee a) \wedge b = x$  by Corollary 13 and it follows that  $\mathbf{L}$  must be the second or third lattice depending on whether  $x \vee c = e$  or not.  $\square$

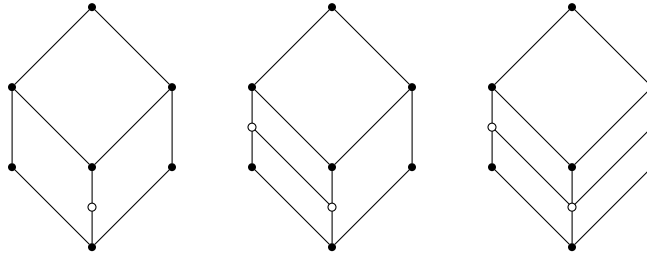

FIGURE 2.

**Lemma 15.** If  $a < x < d$  in  $\mathbf{L}$ , then  $\mathbf{L}$  is isomorphic to the lattice of Figure 3 or to one of the lattices diagrammed in Figure 2.

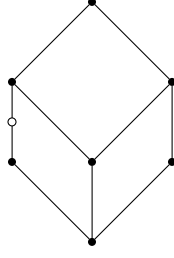

FIGURE 3.

*Proof.* If  $x \wedge b > 0$  then Lemma 14 implies  $\mathbf{L}$  is one of the lattices of Figure 2 and  $x \wedge b = 0$  implies  $\mathbf{L}$  is the lattice of Figure 3.  $\square$

These lemmas show that we may assume

$$(3) \quad a \prec d, 0 \prec b, \text{ and } c \prec e.$$

We now consider the case that  $\mathbf{L}$  has an element  $p$  satisfying  $0 < p < a$ .

**Lemma 16.** *If  $0 < p < a$  in  $\mathbf{L}$ , then  $L = d/p \cup 1/(p \vee c) \cup \{0, b, c, e\}$ .*

*Proof.* Let  $S = d/p \cup 1/p \vee c \cup \{0, b, c, e\}$  and let  $x \in d/p$ . Then  $c \vee x$  and  $e \vee x$  are in  $1/p \vee c$ , and  $b \vee x \in d/p$ . It follows that  $S$  is closed under joins. Since  $d \wedge e = b$ ,  $e \wedge x \in b/0 = \{0, b\}$ . If  $y \in 1/p \vee c$  then  $e \wedge y \in e/c = \{c, e\}$ . Also  $c \wedge y = c$  and  $b \wedge y \in \{0, b\}$ . Clearly  $x \wedge y \in d/p$ . It follows that  $S$  is closed under meets and so is a sublattice. Since it properly contains  $\mathbf{D}_1$ , it must be  $\mathbf{L}$ .  $\square$

As before, this lemma implies  $a/0$  can have at most 3 elements:

**Corollary 17.** *If  $0 < p < a$  then  $a/0 = \{0, p, a\}$ .*

Again assuming  $0 < p < a$ , let

$$S = \{p, (p \vee b) \wedge (p \vee c), d \wedge (p \vee c), p \vee c, \\ p \vee b, b \vee (d \wedge (p \vee c)), d \wedge (p \vee e), p \vee e\};$$

see Figure 4.

The elements of  $S$  need not be distinct in  $\mathbf{L}$  but, as the next lemma shows, they do form a sublattice.

**Lemma 18.** *If  $0 < p < a$ , then  $S$  is a sublattice of  $\mathbf{L}$  which is isomorphic to a homomorphic image of the lattice of Figure 4.*

*Proof.* It is easy to verify that the order relationships of Figure 4 hold. Clearly  $(p \vee b) \vee (p \vee c) = p \vee e$ , and  $[d \wedge (p \vee e)] \wedge (p \vee c) = d \wedge (p \vee c)$ . From this it follows that all the joins and meets of Figure 4 are correct.  $\square$

**Lemma 19.** *If  $0 < p < a$  then  $L = D_1 \cup S$ .*



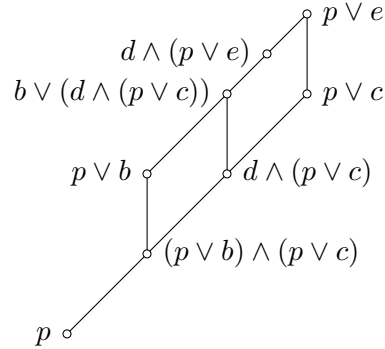

FIGURE 4.  $S$

*Proof.* Let  $x \in S$ . Arguments as in Lemma 16 show that  $e \wedge x$ ,  $c \wedge x$ , and  $b \wedge x$  are all in  $\{0, b, c, e\}$ . It is easy to see that  $d \wedge x \in D_1 \cup S$  and  $a \wedge x$  is either  $p$  or  $a$  by Corollary 17. The remainder of the proof follows easily from Lemma 16.  $\square$

Clearly this implies  $|\mathbf{L}| \leq 15$ . The case when the elements of  $S$  are distinct from each other and from the elements of  $\mathbf{D}_1$  is diagrammed in Figure 5.

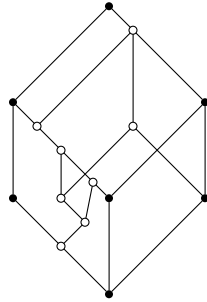

FIGURE 5. The largest minimal extension of  $\mathbf{D}_1$

Consequently we may now make the further assumption

$$(4) \quad 0 \prec a \text{ and } 0 \prec c \text{ in } \mathbf{L}.$$

Arguments that are now standard show that if any of the intervals  $d/b$ ,  $e/b$ ,  $1/d$ , or  $1/e$  are not prime then  $\mathbf{L}$  is isomorphic to one of the lattices of Figure 6.

Thus we may assume every prime interval of  $\mathbf{D}_1$  is prime in  $\mathbf{L}$ . If any interval of length two of  $\mathbf{D}_1$  contains an element of  $L - D_1$ , then  $\mathbf{L}$  must be isomorphic to one of the lattices of Figure 7.

If  $1_{\mathbf{L}} \neq 1_{\mathbf{D}_1}$  then  $\mathbf{L}$  is clearly  $\mathbf{D}_1$  with a new greatest element attached. Similarly we may assume  $0_{\mathbf{L}} = 0_{\mathbf{D}_1}$ . The last possibility is that  $\mathbf{L}$  contains

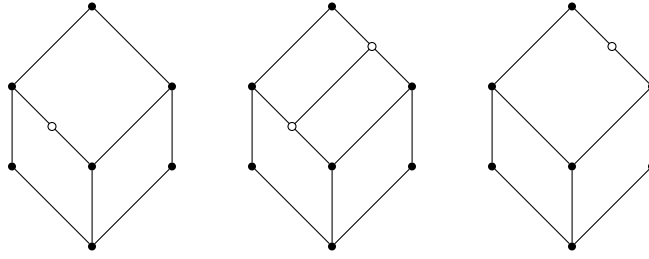

FIGURE 6.

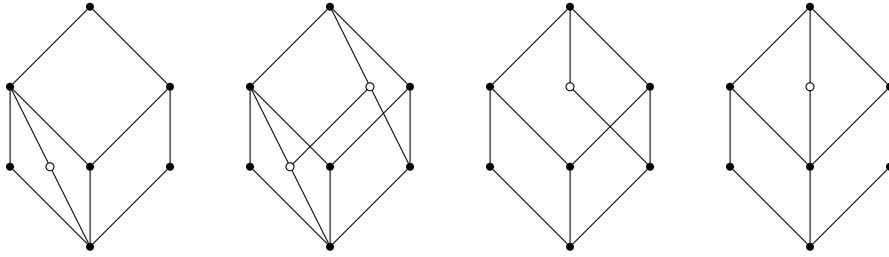

FIGURE 7.

an element whose join with all elements of  $\mathbf{D}_1$  is 1 and whose meet is 0. Of course  $|\mathbf{L}| = |\mathbf{D}_1| + 1$  in this case. This completes the proof of Theorem 10.

**The eight element Boolean algebra.** This lattice, which is diagrammed in Figure 8, is also small. One can make a proof similar to that of Theorem 10, but we do something different for variety.

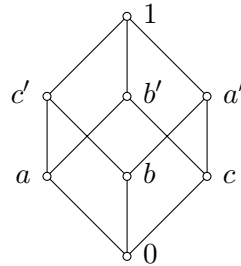

FIGURE 8.  $\mathbf{B}_3$

**Theorem 20.** *If  $\mathbf{B}_3$  is a maximal sublattice of a lattice  $\mathbf{L}$ , then  $|\mathbf{L}| \leq 14$ .*

**Lemma 21.** *Let  $\mathbf{K}$  be a finite lattice and let  $c$  be a join prime element in  $\mathbf{K}$ . Let  $c_{\dagger}$  denote the lower cover of  $c$  in  $\mathbf{K}$ . If  $\mathbf{K}$  is a maximal sublattice of  $\mathbf{L}$ , then either  $c \succ c_{\dagger}$  in  $\mathbf{L}$  or there is a unique element  $p$  in  $L - K$  such that  $c_{\dagger} < p < c$ .*

*Proof.* Suppose  $c_{\dagger} < p < c$  in  $\mathbf{L}$ . Let  $\kappa(c) = \bigvee\{x \in K : x \not\geq c\}$ . Since  $c$  is join prime,  $\kappa(c) \not\geq c$ . Since  $\mathbf{L} = \mathbf{Sg}(K \cup \{p\})$ , we can prove inductively that for all  $x \in L$ , either  $x \geq p$  or  $x \leq \kappa(c)$ . This implies that if  $c_{\dagger} < q \leq c$  then  $p \leq q$ . By symmetry  $q \leq p$ .  $\square$

This lemma implies that if  $\mathbf{B}_3$  is a maximal sublattice of  $\mathbf{L}$  then each atom can contain at most one element not in  $\mathbf{B}_3$ . So suppose  $0 < p < b$  in  $\mathbf{L}$ . The lattice  $\mathbf{F}$  freely generated by  $\mathbf{B}_3$  and such a  $p$  is diagrammed in Figure 9. This can be verified with the results of [4].

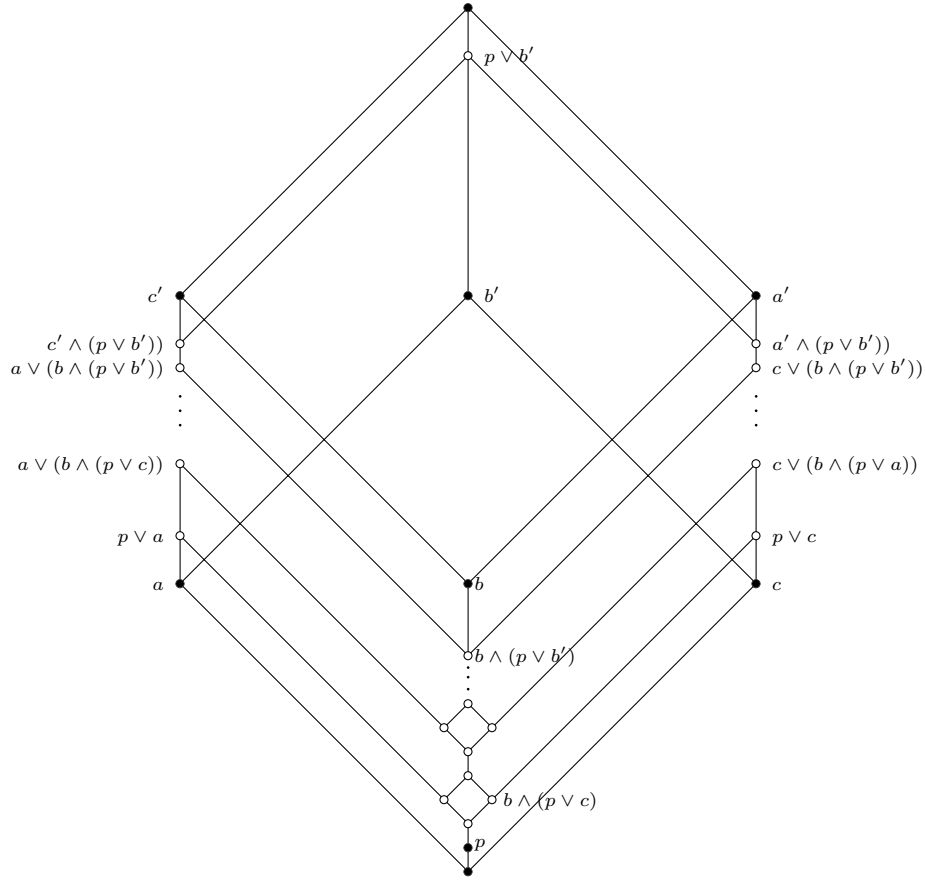

FIGURE 9. The free lattice generated by  $\mathbf{B}_3$  and  $p$ ,  $0 \leq p \leq b$ .

Now  $\mathbf{L}$  is  $\mathbf{F}/\theta$  for some congruence  $\theta$  on  $\mathbf{F}$  and of course  $\theta$  restricted to the interval  $b/0$  must have three blocks with  $0$ ,  $b$  and  $p$  in distinct blocks. This implies that  $0$  is in a block by itself. Of course each block is a convex sublattice of  $b/0$ . It turns out there are only 5 possibilities. These generate 5 congruences, denoted  $\theta_0$  to  $\theta_4$ . The  $p$ -block of each of these congruences

is:

$$\begin{aligned} p/\theta_0 &= \{p\} \\ p/\theta_1 &= \{x : p \leq x \leq b \wedge (p \vee a)\} \\ p/\theta_2 &= \{x : p \leq x \leq b \wedge (p \vee c)\} \\ p/\theta_3 &= \{x : p \leq x < b \wedge (p \vee b')\} \\ p/\theta_4 &= \{x : p \leq x \leq b \wedge (p \vee b')\} \end{aligned}$$

The key to seeing that these are the only possibilities is that if  $p/\theta$  contains both  $b \wedge (p \vee a)$  and  $b \wedge (p \vee c)$ , it contains all elements  $x$  with  $p \leq x < b \wedge (p \vee b')$ , which is easily verified; see Figure 9.

The lattices  $\mathbf{F}/\theta_i$ ,  $i = 0, 2, 3$ , and  $4$ , are given in Figure 10. (Since  $\mathbf{F}/\theta_1 \cong \mathbf{F}/\theta_2$  only one is drawn.)  $\mathbf{B}_3$  is a maximal sublattice of each of these lattices. (Actually, using Lemma 9, one can show that this must be the case.) So our lattice  $\mathbf{L}$  must be one of these lattices or a homomorphic image of one of them that separates  $B_3 \cup \{p\}$ . Only the last of these lattices, i.e.,  $\mathbf{F}/\theta_4$ , has any such homomorphic image. In that lattice  $p \vee c$  can be collapsed to its upper cover,  $p \vee a$  can be collapsed to its upper cover, and of course both can be collapsed.

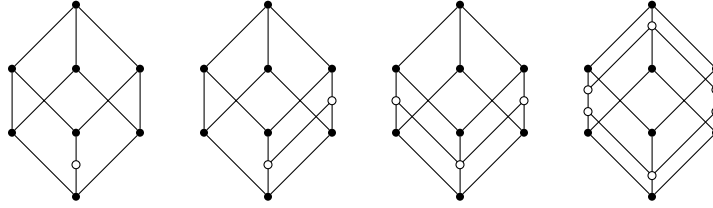

FIGURE 10.  $\mathbf{F}/\theta_i$  for  $i = 0, 2, 3$ , and  $4$ .

Thus we have shown that if  $0 < p < b$  in  $\mathbf{L}$  then  $|L| \leq 14$ . So by symmetry and duality we may assume that  $a$ ,  $b$ , and  $c$  each cover  $0$  in  $\mathbf{L}$  and each coatom of  $\mathbf{B}_3$  is covered by  $1$  in  $\mathbf{L}$ . If  $a < p < a \vee b$  then all these coverings imply  $L = B_3 \cup \{p\}$  and so we may assume every covering of  $\mathbf{B}_3$  is a covering of  $\mathbf{L}$ . Now using arguments similar to those for  $\mathbf{D}_1$  we can show that if  $0 < p < a \vee b$ , then  $\mathbf{L}$  is  $\mathbf{M}_3 \times \mathbf{2}$  or  $L - B_3$  only has  $p$ . Thus we may assume that all intervals of length  $2$  of  $\mathbf{B}_3$  intersect  $L$  trivially. So if  $0 < p < 1$  then it is the only element of  $L - B_3$ . Finally if either the least element of  $\mathbf{B}_3$  is not the least element of  $\mathbf{L}$  or the dual situation holds,  $|L| = 9$ . This completes the proof of Theorem 20.

**Small distributive lattices.** Let  $\mathbf{n}$  denote the  $n$  element chain. Clearly  $\mathbf{n}$  is small for any  $n$ . Likewise,  $\mathbf{2} \times \mathbf{n}$  is a small lattice for any  $n \leq 5$ . The largest minimal extension of  $\mathbf{2} \times \mathbf{5}$  is shown in Figure 11.

**Theorem 22.** *Let  $\mathbf{n}$  denote the  $n$  element chain.*

1. *If  $\mathbf{n}$  is a maximal sublattice of  $\mathbf{L}$ , then  $|\mathbf{L}| = n + 1$ .*

2. If  $\mathbf{2} \times \mathbf{2}$  is a maximal sublattice of  $\mathbf{L}$ , then  $|\mathbf{L}| \leq 6$ .
3. If  $\mathbf{2} \times \mathbf{3}$  is a maximal sublattice of  $\mathbf{L}$ , then  $|\mathbf{L}| \leq 10$ .
4. If  $\mathbf{2} \times \mathbf{4}$  is a maximal sublattice of  $\mathbf{L}$ , then  $|\mathbf{L}| \leq 16$ .
5. If  $\mathbf{2} \times \mathbf{5}$  is a maximal sublattice of  $\mathbf{L}$ , then  $|\mathbf{L}| \leq 28$ .

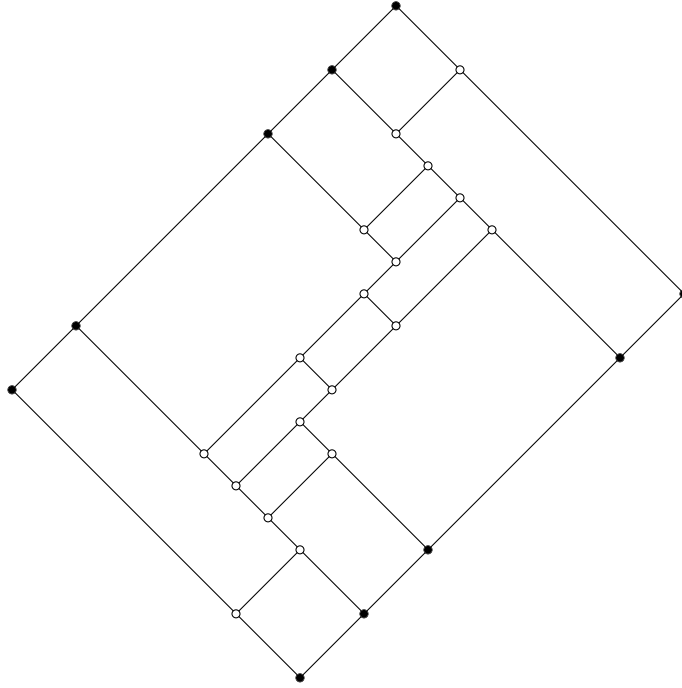

FIGURE 11. The largest minimal extension of  $\mathbf{2} \times \mathbf{5}$ .

These bounds are a consequence of Theorem 49. Moreover, our later analysis will prove the following result.

**Theorem 23.** *A finite modular lattice  $\mathbf{D}$  is small if and only if  $\mathbf{D}$  is distributive and contains neither  $\mathbf{2} \times \mathbf{6}$  ( $= \mathbf{G}_{54}$ ), nor  $\mathbf{G}_3$ , nor its dual as a sublattice.*

**More small lattices (of width 2).** Let  $\mathbf{N}_{kl}$  be the lattice whose order is the union of two chains  $0 < a_1 < \cdots < a_k < 1$  and  $0 < b_1 < \cdots < b_l < 1$ , with no other elements or relations. Thus  $\mathbf{N}_{12}$  is a pentagon, and  $\mathbf{N}_{23}$  is the lattice in Figure 12. Using arguments like those in the proof that  $\mathbf{D}_1$  is small (and Lemma 21), one can show that some of these lattices are small. See Figures 13 and 14.

**Theorem 24.** *Let  $\mathbf{N}_{kl}$  be as defined above.*

1. If  $\mathbf{N}_{1k}$  is a maximal sublattice of  $\mathbf{L}$ , then  $|\mathbf{L}| \leq 2k + 4$ .
2. If  $\mathbf{N}_{22}$  is a maximal sublattice of  $\mathbf{L}$ , then  $|\mathbf{L}| \leq 12$ .

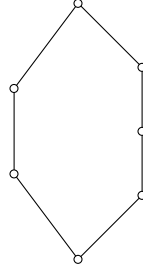
FIGURE 12.  $\mathbf{N}_{23}$ 

3. If  $\mathbf{N}_{23}$  is a maximal sublattice of  $\mathbf{L}$ , then  $|\mathbf{L}| \leq 18$ .
4. If  $\mathbf{N}_{24}$  is a maximal sublattice of  $\mathbf{L}$ , then  $|\mathbf{L}| \leq 30$ .

Again, these bounds are a consequence of Theorem 49. However, as we will see in a later section, if  $k = 2$  and  $l \geq 5$ , or if both  $k$  and  $l$  are at least 3, then  $\mathbf{N}_{kl}$  is big.

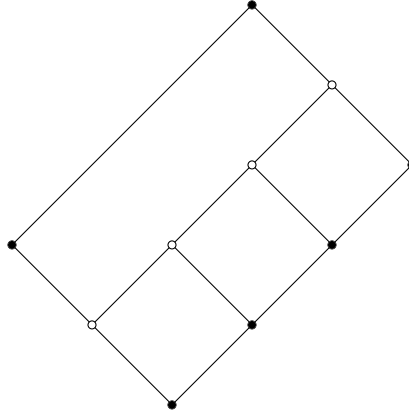
FIGURE 13. The largest minimal extension of  $\mathbf{N}_{13}$ .

## 6. BIG LATTICES

It is often useful, when  $\mathbf{L}$  is a maximal sublattice of  $\mathbf{K}$ , to think of  $\mathbf{K}$  as a gluing of  $\mathbf{L}$  and the ordered set  $\mathbf{F} = \mathbf{K} - \mathbf{L}$ . The following technical lemma gives sufficient conditions for reversing this process to construct big lattices.

**Lemma 25.** *Let  $\mathbf{L}$  be a finite lattice and  $\mathbf{F}$  an ordered set. Let  $\alpha, \beta : \mathbf{F} \rightarrow \mathbf{L}$  be maps satisfying the following conditions.*

1. For all  $w \in F$ ,  $\beta(w) < \alpha(w)$ .
2. For all  $u, v \in F$ ,  $\alpha(u) \not\leq \beta(v)$ .
3. For all  $u, v \in F$ ,  $u \leq v$  implies  $\beta(u) \leq \beta(v)$ .
4. For all  $u, v \in F$ ,  $u \leq v$  implies  $\alpha(u) \leq \alpha(v)$ .

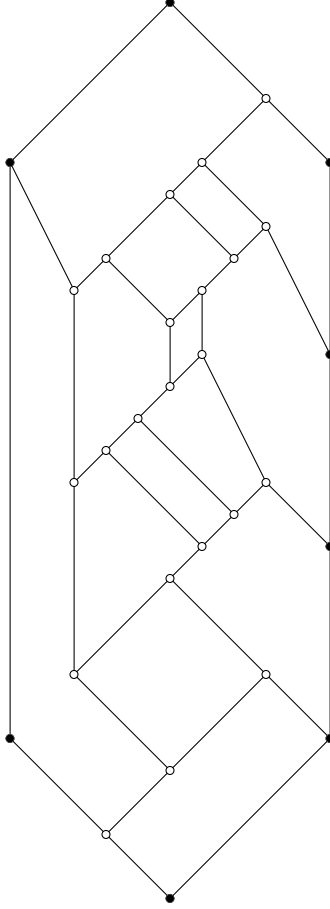
FIGURE 14. The largest minimal extension of  $\mathbf{N}_{24}$ .

5. If  $u, v \in F$  have a lower bound in  $\mathbf{F}$ , then  $u \wedge v$  exists in  $\mathbf{F}$  and  $\beta(u \wedge v) = \beta(u) \wedge \beta(v)$ .
6. If  $u, v \in F$  have an upper bound in  $\mathbf{F}$ , then  $u \vee v$  exists in  $\mathbf{F}$  and  $\alpha(u \vee v) = \alpha(u) \vee \alpha(v)$ .
7. For  $u \in F, x \in L$  put  $V_{ux} = \{v \in F : u \leq v, x \leq \beta(v)\}$ . If  $V_{ux} \neq \emptyset$ , then  $V_{ux}$  contains a least element  $v_0$  and  $\alpha(v_0) \leq \alpha(u) \vee x$ .
8. For  $u \in F, x \in L$  put  $W_{ux} = \{w \in F : u \geq w, x \geq \alpha(w)\}$ . If  $W_{ux} \neq \emptyset$ , then  $W_{ux}$  contains a greatest element  $w_1$  and  $\beta(w_1) \geq \beta(u) \wedge x$ .

Define an order on the disjoint union  $\mathbf{L} \dot{\cup} \mathbf{F}$  by, for  $x, y \in L$  and  $u, v \in F$ ,

$$\begin{aligned}
 x \leq y & \text{ iff } x \leq y \text{ in } \mathbf{L}, \\
 u \leq v & \text{ iff } u \leq v \text{ in } \mathbf{F}, \\
 x \leq v & \text{ iff } x \leq \beta(v) \text{ in } \mathbf{L}, \\
 u \leq y & \text{ iff } \alpha(u) \leq y \text{ in } \mathbf{L}.
 \end{aligned}$$

Then  $\mathbf{L} \dot{\cup} \mathbf{F}$  is a lattice.

The proof is straightforward. Conditions 1–4 ensure that  $\leq$  is a partial order; condition 2 can be weakened but holds as written in our applications. Note that condition 2 makes  $\mathbf{F}$  a convex subset of  $\mathbf{L} \dot{\cup} \mathbf{F}$ . Conditions 5 and 6 ensure that finite meets and joins defined in  $\mathbf{F}$  remain so in  $\mathbf{L} \dot{\cup} \mathbf{F}$ . Conditions 7 and 8 ensure that  $u \vee x$  and  $u \wedge x$ , respectively, are defined for  $u \in F$ ,  $x \in L$ . For example, for  $y \in L$  we have  $y \geq u$  and  $y \geq x$  if and only if  $y \geq \alpha(u) \vee x$ ; on the other hand, for  $v \in F$  we have  $v \geq u$  and  $v \geq x$  if and only if  $v \in V_{ux}$  if and only if  $v \geq v_0$ . Condition 7 says that  $\alpha(u) \vee x \geq \alpha(v_0)$  when  $V_{ux}$  is nonempty, so that  $u \vee x = v_0$  in  $\mathbf{L} \dot{\cup} \mathbf{F}$ .

It is useful to record the operations of  $\mathbf{L} \dot{\cup} \mathbf{F}$ . For  $x, y \in L$  and  $u, v \in F$ ,

1.  $x \wedge y$  is the same as in  $\mathbf{L}$ ,
2.  $u \wedge v$  is the same as in  $\mathbf{F}$  if  $u$  and  $v$  have a lower bound in  $\mathbf{F}$ , and is  $\beta(u) \wedge \beta(v)$  otherwise,
3.  $u \wedge x$  is  $\beta(u) \wedge x$  if  $W_{ux}$  is empty, and is  $w_1 (= \bigvee W_{ux})$  otherwise.

Joins are dual. Thus  $\mathbf{L}$  is a sublattice of  $\mathbf{L} \dot{\cup} \mathbf{F}$ , and the order is such that  $\alpha(u) = u^{[\mathbf{L}]}$  and  $\beta(u) = u_{[\mathbf{L}]}$  for each  $u \in F$ .

**The construction.** Next we present a general argument which can be used to show that many lattices are big. If  $\mathbf{P}$  is a finite partial lattice, let  $\mathbf{FL}(\mathbf{P})$  denote the finitely presented lattice generated by  $\mathbf{P}$ .

**Theorem 26.** *Let  $\mathbf{L}$  be a finite lattice and let  $x, y$  be incomparable elements of  $\mathbf{L}$ . Let  $A = (x \vee y)/x$  and  $B = y/(x \wedge y)$ . Define a partial lattice  $\mathbf{Q}_{\mathbf{L}}(x, y)$  as follows. The elements of  $\mathbf{Q}_{\mathbf{L}}(x, y)$  are*

$$\{q_c : c \in A \cup B\}$$

with  $q_x = q_{x \wedge y}$  and  $q_y = q_{x \vee y}$ . The relations are

$$\begin{aligned} q_a \wedge q_{a'} &= q_{a \wedge a'} & \text{for } a, a' \in A, \\ q_b \vee q_{b'} &= q_{b \vee b'} & \text{for } b, b' \in B, \\ q_b &\leq q_a & \text{if } b \in B, a \in A, b \leq a. \end{aligned}$$

Then there are maps  $\alpha, \beta : \mathbf{FL}(\mathbf{Q}_{\mathbf{L}}(x, y)) \rightarrow \mathbf{L}$  such that  $\mathbf{L} \dot{\cup} \mathbf{FL}(\mathbf{Q}_{\mathbf{L}}(x, y))$  is a minimal extension of  $\mathbf{L}$ . In particular, if the finitely presented lattice  $\mathbf{FL}(\mathbf{Q}_{\mathbf{L}}(x, y))$  is infinite, then  $\mathbf{L}$  is big.

Whenever the context is clear, we will write  $\mathbf{FQ}(x, y)$  for  $\mathbf{FL}(\mathbf{Q}_{\mathbf{L}}(x, y))$ . Figures 15 and 16 illustrate this construction. In each case the figure on the right is the diagram of the ordered set associated with  $\mathbf{Q}_{\mathbf{L}}(x, y)$ . The defined joins and meets are listed to the right. For example, in  $\mathbf{G}_{22}$ ,  $a \wedge b = x$  so, in  $\mathbf{Q}_{\mathbf{L}}(x, y)$ ,  $q_a \wedge q_b = q_x = q_{x \wedge y} = 0$ . We claim in both cases the finitely presented lattice  $\mathbf{FL}(\mathbf{Q}_{\mathbf{L}}(x, y))$  is infinite. How do we decide if a finitely presented lattice is infinite? Of course we need to do this for all 145 of our minimal big lattices. For a join trivial finite presented lattice we can use the method of [6]. But for lattices such as  $\mathbf{G}_2$  and  $\mathbf{G}_{22}$  we use a different method. We first enter the partial lattice  $\mathbf{Q}_{\mathbf{L}}(x, y)$  into our lattice program



for finitely presented lattice and close it under joins, then meets, then joins, etc. If this stops then of course the finitely presented lattice is finite. For the case  $\mathbf{L} = \mathbf{G}_2$  the partial lattice has 8 elements, its join closure 11 elements. The meet closure of that has 13 elements, etc. The sequence begins 8, 11, 13, 16, 21, 27, 36, 85, 1646, ... While this strongly suggest the lattice is infinite, it does not prove it.

However, our program can test if a join irreducible element of a finitely presented lattice is completely join irreducible, i.e., if it has a lower cover, using the algorithm of [4]. The algorithm shows that  $q_b$  is join irreducible but not completely join irreducible, proving that  $\mathbf{FL}(\mathbf{Q}_{\mathbf{L}}(x, y))$  is infinite for  $\mathbf{L} = \mathbf{G}_2$ .

For  $\mathbf{L} = \mathbf{G}_{22}$  the growth sequence is 8, 12, 31, 229, ... In this case  $q_a$  is join irreducible but not completely join irreducible.<sup>1</sup>

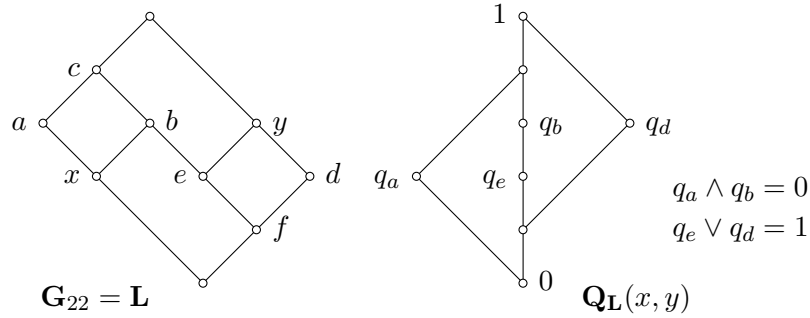

FIGURE 15.

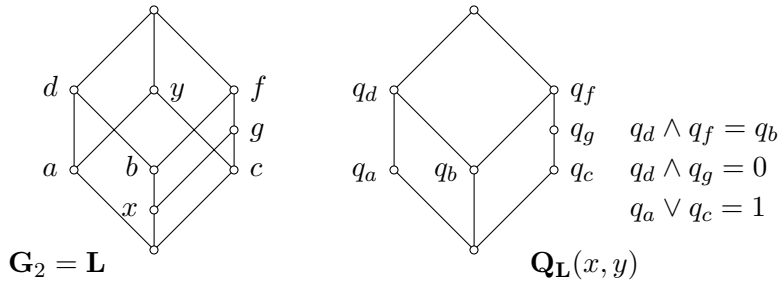

FIGURE 16.

<sup>1</sup>There are some interesting related questions. First, *if a finitely presented lattice has the property that every join irreducible element is completely join irreducible and dually, is it finite?*

We have also observed that the growth rate of the sequence of join and meet closures of a finitely presented lattice appears to be one of three types. Either it stops (and the lattice is finite), it grows linearly, or it grows exponentially. (An example of linear growth is  $\mathbf{G}_1$  which has a sequence 7, 9, 12, 15, 18, 21, 24, 27, 30, 33, ...) This raises the question: *is this tricotomy valid?*

*Proof.* First note that  $\mathbf{Q}(x, y)$  is a partial lattice. For  $A \cup B$  is a sublattice of  $\mathbf{L}$ , and we have a model  $\hat{\mathbf{Q}}$  of  $\mathbf{Q}(x, y)$  sitting inside of  $\mathbf{L}$ , with universe  $\hat{\mathbf{Q}} = (A \cup B) - \{x, y\}$  and its inherited order. (We can think of either removing  $x$  and  $y$ , or identifying them with  $x \wedge y$  and  $x \vee y$  respectively.)  $\hat{\mathbf{Q}}$  is a lattice, and there is a natural homomorphism  $h : \mathbf{FQ}(x, y) \rightarrow \hat{\mathbf{Q}}$  with  $h(q_x) = x \wedge y$ ,  $h(q_y) = x \vee y$ , and  $h(q_t) = t$  otherwise.

We use Lemma 25 to glue  $\mathbf{FQ}(x, y)$  into  $\mathbf{L}$ . We begin by defining maps  $\alpha_0 : \mathbf{Q}(x, y) \rightarrow A$  and  $\beta_0 : \mathbf{Q}(x, y) \rightarrow B$  as follows:

$$\begin{aligned} \alpha_0(q_a) &= a && \text{for } a \in A, \\ \alpha_0(q_b) &= x \vee b && \text{for } b \in B, \\ \beta_0(q_a) &= y \wedge a && \text{for } a \in A, \\ \beta_0(q_b) &= b && \text{for } b \in B. \end{aligned}$$

Note that  $\alpha_0$  and  $\beta_0$  are well-defined on the identified elements  $q_x = q_{x \wedge y}$  and  $q_y = q_{x \vee y}$ . Check that  $\alpha_0$  and  $\beta_0$  preserve the relations defining  $\mathbf{Q}(x, y)$ , and thus they can be extended to homomorphisms  $\alpha : \mathbf{FQ}(x, y) \rightarrow A$  and  $\beta : \mathbf{FQ}(x, y) \rightarrow B$ .

Next we verify that  $\alpha$  and  $\beta$  satisfy the conditions of Lemma 25. The first six conditions are immediate, using the fact that  $\alpha$  and  $\beta$  are homomorphisms. Condition 7 requires a lemma.

**Lemma 27.** *For  $v \in \mathbf{FQ}(x, y)$  and  $t \in L$  with  $t \leq y$ , we have  $t \leq \beta(v)$  if and only if  $q_{z \vee t} \leq v$ , where  $z = x \wedge y$ .*

*Proof.* If  $q_{z \vee t} \leq v$ , then  $t \leq z \vee t = \beta(q_{z \vee t}) \leq \beta(v)$ .

The converse is proved by induction on the complexity of  $v$ . If  $v = q_a$  where  $a \in A$ , then  $t \leq \beta(q_a) = y \wedge a$  implies  $z \vee t \leq y \wedge a$ , whence  $q_{z \vee t} \leq q_{y \wedge a} \leq q_a$ . The case  $v = q_b$  with  $b \in B$  is similar. If  $v = v_1 \wedge v_2$  and  $t \leq \beta(v_1 \wedge v_2) = \beta(v_1) \wedge \beta(v_2)$ , then  $z \vee t \leq \beta(v_1), \beta(v_2)$ . By induction  $q_{z \vee t} \leq v_1, v_2$  whence  $q_{z \vee t} \leq v_1 \wedge v_2$ . Finally, suppose  $t \leq \beta(v_1 \vee v_2) = \beta(v_1) \vee \beta(v_2)$ . Then  $z \vee t \leq \beta(v_1) \vee \beta(v_2)$ , so  $q_{z \vee t} \leq q_{\beta(v_1) \vee \beta(v_2)} = q_{\beta(v_1)} \vee q_{\beta(v_2)}$ . However, by induction with  $t = \beta(v_i)$  we have  $q_{\beta(v_i)} \leq v_i$ , whence  $q_{z \vee t} \leq v_1 \vee v_2$ .  $\square$

For condition 7, suppose that  $V_{ut}$  is nonempty. Then  $v \in V_{ut}$  if and only if  $u \leq v$  and  $q_{z \vee t} \leq v$ , so that  $v_0 = u \vee q_{z \vee t}$  is the least element of  $V_{ut}$ . Then  $\alpha(v_0) = \alpha(u) \vee x \vee z \vee t = \alpha(u) \vee t$ , as desired. Condition 8 is dual.

It remains to show that  $\mathbf{L}$  is maximal in  $\mathbf{L} \dot{\cup} \mathbf{FQ}(x, y)$ . First note that for any  $u \in \mathbf{FQ}(x, y)$ ,  $x \wedge u = q_x$ , and hence  $q_x \in \text{Sg}(L \cup \{u\})$ . On the other hand, for  $b \in B$  we have  $q_x \vee b = q_b$ . This includes  $q_{x \vee y} = q_y$ , and for  $a \in A$  we have  $q_y \wedge a = q_a$ . (These calculations all use Lemma 27 and its dual:  $\alpha(u) \leq a$  implies  $u \leq q_a$  and  $\beta(v) \geq b$  implies  $v \geq q_b$ .) Thus  $\mathbf{Q}(x, y) \subseteq \text{Sg}(L \cup \{q_x\}) \subseteq \text{Sg}(L \cup \{u\})$ , and it follows that  $\text{Sg}(L \cup \{u\}) = \mathbf{L} \dot{\cup} \mathbf{FQ}(x, y)$  for any  $u \in \mathbf{FQ}(x, y)$ , so  $\mathbf{L}$  is a maximal sublattice.  $\square$

The construction of the preceding theorem is illustrated in Figures 11, 13 and 14. In each of these cases  $\mathbf{FQ}(x, y)$  is finite and the construction gives

the largest minimal extension. If, however, we take  $\mathbf{L} = \mathbf{N}_{33}$  and let  $x$  be an atom and  $y = \kappa(x)$  a coatom, then  $\mathbf{Q}(x, y)$  is order isomorphic to  $\mathbf{N}_{22}$  with no nontrivial meets or joins defined. Then  $\mathbf{FQ}(x, y)$  is isomorphic to  $\mathbf{FL}(2 + 2)$  with a new 0 and 1, which is infinite. Thus  $\mathbf{N}_{33}$  is big. Likewise, if  $\mathbf{L} = \mathbf{N}_{25}$ , then  $\mathbf{Q}(x, y)$  is order isomorphic to  $\mathbf{N}_{14}$ , and  $\mathbf{FQ}(x, y)$  is again infinite, so  $\mathbf{N}_{25}$  is big.

Now we can show that all the lattices in our list of minimal big lattices are indeed big.

**Theorem 28.** *All the lattices  $\mathbf{G}_i$  with  $1 \leq i \leq 81$  are big.*

*Proof.* There are five types of minimal big lattices (eight lattices counting duals) which require special constructions to show that they are a maximal sublattice of an infinite lattice.

The lattices  $\mathbf{G}_{13}$  and  $\mathbf{G}_9$  are drawn in Figure 17. Infinite minimal extensions of these two lattices are given in Figure 18.

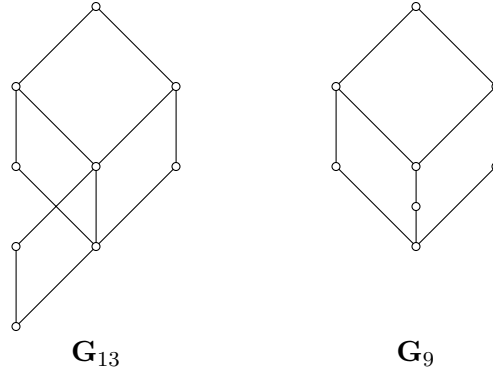

FIGURE 17.

Another *ad hoc* variation of the construction shows that the The lattices  $\mathbf{M}_3 = \mathbf{G}_5$  and  $\mathbf{G}_6$  in Figure 19 are big. Infinite lattices with  $\mathbf{M}_3$  and  $\mathbf{G}_6$  (respectively) as maximal sublattices are given in Figures 20 and 21.

The last special construction, illustrated in Figure 22, shows that the lattice  $\mathbf{G}_7$  is big.

Now we turn to applications of the general construction of Theorem 26. We can show that  $\mathbf{G}_1$ ,  $\mathbf{G}_2$  and  $\mathbf{G}_3$  are big as follows. For  $\mathbf{G}_1$  and  $\mathbf{G}_2$ , let  $x$  be the middle atom (as the lattice is drawn in the figures); for  $\mathbf{G}_3$  let  $x$  be the atom on the left. In each case, let  $y = \kappa(x)$ , which will be a coatom. Let  $b$  be the meet of the other two coatoms. Applying the algorithms in Freese [4], we find that  $q_b$  is join irreducible, but not completely join irreducible, in  $\mathbf{FQ}(x, y)$ . Hence, in these three cases,  $\mathbf{FQ}(x, y)$  is infinite and  $\mathbf{G}_i$  is big.

FIGURE 18. Minimal extensions of  $\mathbf{G}_{13}$  and  $\mathbf{G}_9$ .

FIGURE 19.

Likewise, in the drawing of  $\mathbf{G}_{22}$  let  $x$  be the atom on the left,  $y = \kappa(x)$ , and let  $b$  be the left upper cover of  $x$ . Again we find that  $q_b$  is join irreducible, but not completely join irreducible, in  $\mathbf{FQ}(x, y)$ , whence  $\mathbf{G}_{22}$  is big.

For all the rest, there is a natural choice of  $x$  and  $y$  such that  $L = (x \vee y)/x \cup y/(x \wedge y)$  and  $\mathbf{Q}(x, y)$  is either join trivial or meet trivial. (A partial lattice is *join trivial* if its presentation contains no proper joins.) In the figures,  $x$  is drawn as the atom on the left, and  $y = \kappa(x)$  is the coatom on the right. In each case,  $\mathbf{Q}(x, y)$  or its dual fails the conditions of Ježek and Slavík [6] for the finitely presented lattice generated by a join trivial

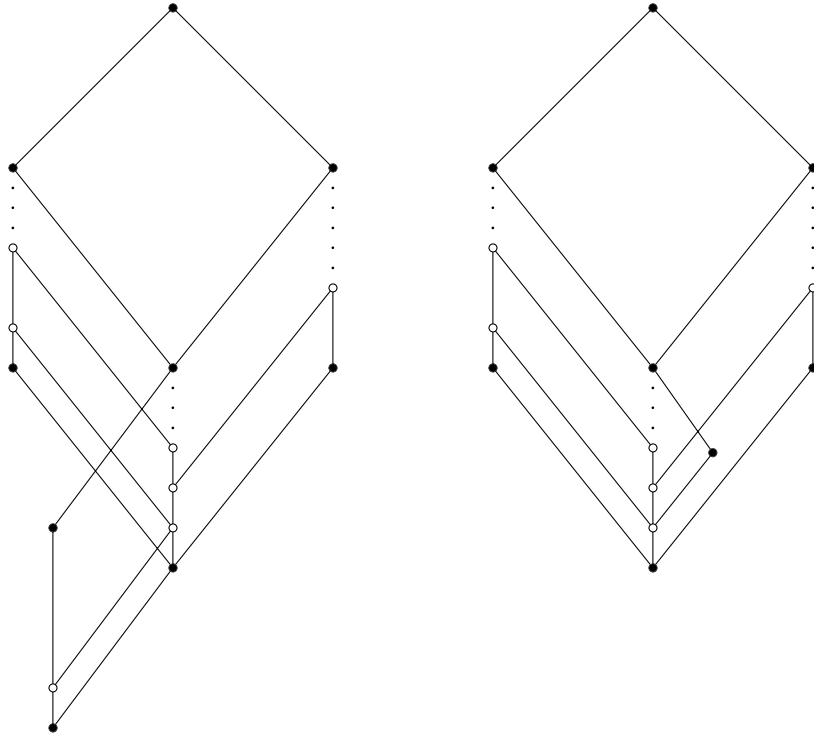
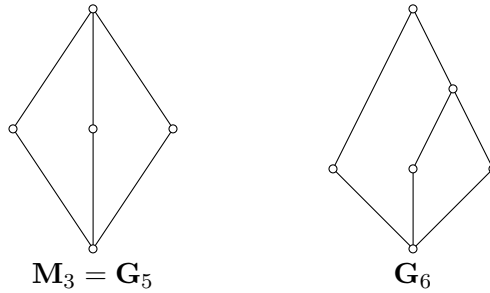
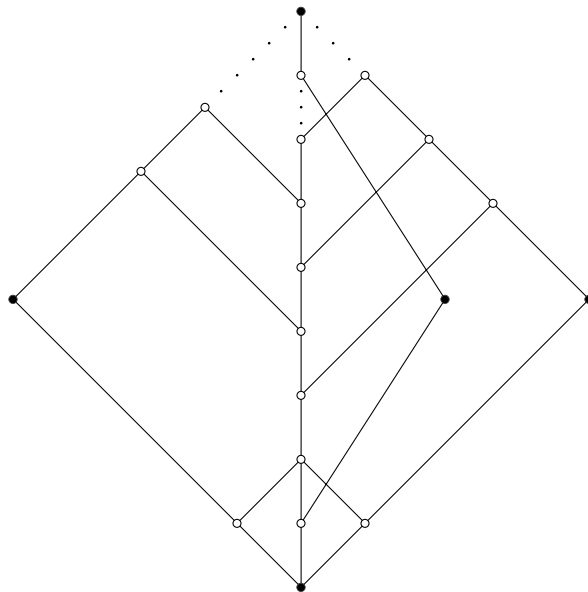

FIGURE 20. An infinite minimal extension of  $\mathbf{M}_3$ .

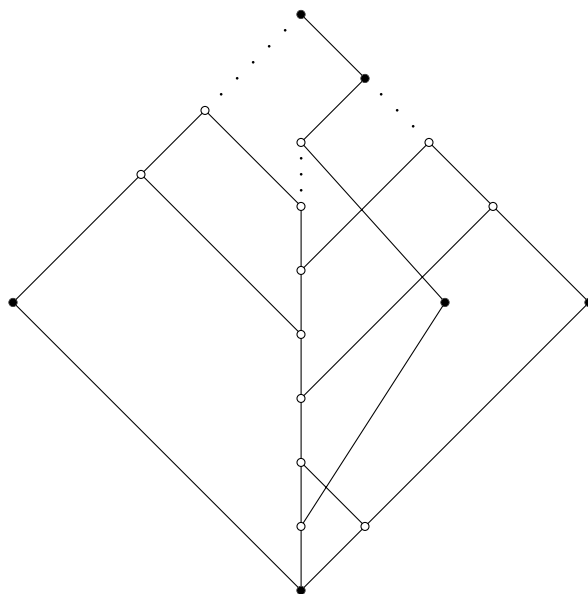
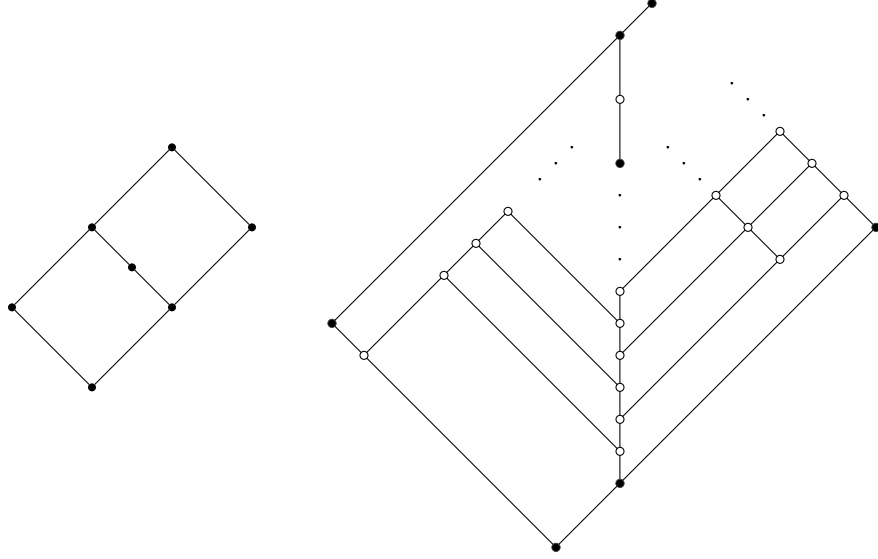

FIGURE 21. An infinite minimal extension of  $\mathbf{G}_6$ .

partial lattice to be finite, which are given as Lemma 61 below. Note that the lattices  $\mathbf{G}_{68}$ ,  $\mathbf{G}_{69}$ ,  $\mathbf{G}_{78}$ ,  $\mathbf{G}_{79}$ ,  $\mathbf{G}_{80}$ , and  $\mathbf{G}_{81}$  are actually planar even though our diagrams are not. We use these diagrams so that the choice of  $x$  and  $y$  are the left atom and right coatom, respectively.  $\square$

FIGURE 22.  $\mathbf{G}_7$  and an infinite minimal extension.

For later reference, we need one more fact.

**Lemma 29.** *If  $\mathbf{Q}(x, y)$  is as in Theorem 26, then the finitely presented lattice  $\mathbf{FQ}(x, y)$  satisfies Whitman's condition (W).*

*Proof.* Let  $Q_A = \{q_a : a \in A\}$  and  $Q_B = \{q_b : b \in B\}$ . We show that, for  $s_i, t_j \in \mathbf{FQ}(x, y)$  and  $q \in Q(x, y)$ ,

1.  $\bigwedge s_i \leq q$  implies  $\bigwedge s_i = q_x$  or  $s_i \leq q$  for some  $i$  or  $q \in Q_A$ ,
2.  $\bigvee t_j \geq q$  implies  $\bigvee t_j = q_y$  or  $t_j \geq q$  for some  $j$  or  $q \in Q_B$ .

Since  $q_a \leq q_b$  holds only if  $a = x$  or  $b = y$ , it follows from the solution to the word problem for finitely presented lattices that (W) holds in  $\mathbf{FQ}(x, y)$ . (See e.g. [5], Chapter XI, Section 9.)

Recall that for  $s \in \mathbf{FQ}(x, y)$  and  $q \in Q(x, y)$ ,  $s \leq q$  is defined inductively. The relations with  $s$  a generator are given, and  $\bigvee s_j \leq q$  holds if  $s_j \leq q$  for all  $j$ . The relation  $\bigwedge s_i \leq q$  holds if and only if  $q \in \text{Fil}(s_1, \dots, s_m)$  where  $\text{Fil}(s_1, \dots, s_m)$  is the order filter of  $\mathbf{Q}(x, y)$  defined by

1.  $F_0 = \{p \in Q(x, y) : s_i \leq p \text{ for some } i\}$ ,
2.  $F_{k+1} = \{p \in Q(x, y) : \bigwedge Z \leq p \text{ for some } Z \subseteq F_k\}$ ,
3.  $\text{Fil}(s_1, \dots, s_m) = \bigcup_{k \geq 0} F_k$ .

Suppose  $q \in \text{Fil}(s_1, \dots, s_m)$  and  $q_x \in \text{Fil}(s_1, \dots, s_m)$ . If  $q \in F_0$ , then  $s_i \leq q$  for some  $i$ . If  $q \in F_{k+1} - F_k$ , then  $\bigwedge Z \leq q$  for some proper meet of elements  $Z \subseteq F_k$ . The only proper meets defined in  $\mathbf{Q}(x, y)$  are for subsets of  $Q_A$ . Thus  $Z \subseteq Q_A$ , and since  $\bigwedge Z \neq q_x$ , we conclude  $q \in Q_A$ .  $\square$

## 7. REDUCTION TO BREADTH 2

Recall that the *breadth* of a finite lattice  $\mathbf{L}$ , denoted  $\text{br}(\mathbf{L})$ , is the largest number  $n$  such that  $L$  contains an  $n$ -element join irredundant set. Two basic facts about breadth are these.

1. If  $X$  is an  $n$ -element join irredundant set, then the set  $\overline{X}$  of elements  $\overline{x} = \bigvee(X - \{x\})$  is an  $n$ -element meet irredundant set.
2. If  $\text{br}(\mathbf{L}) \geq 3$ , then  $\mathbf{L}$  contains a sublattice isomorphic to the eight-element Boolean algebra  $\mathbf{B}_3$ .

We will show that every finite, linearly indecomposable lattice of breadth 3 or more, except  $\mathbf{B}_3$  itself, is big.

**Theorem 30.** *If  $\mathbf{L}$  is a finite, linearly indecomposable lattice with  $\text{br}(\mathbf{L}) \geq 3$ , then either  $\mathbf{L} \cong \mathbf{B}_3$  or  $\mathbf{L}$  contains a sublattice isomorphic to one of the big lattices  $\mathbf{G}_i$  with  $1 \leq i \leq 8$  or their duals.*

*Proof.* Assume that  $\mathbf{L}$  is finite and linearly indecomposable, and that  $\text{br}(\mathbf{L}) \geq 3$ . Then  $\mathbf{L}$  contains a sublattice  $\mathbf{B} = \{z, a, b, c, d, e, f, u\}$  isomorphic to  $\mathbf{B}_3$  as in Figure 23. Moreover, we can choose this sublattice so that every proper subinterval of  $u/z$  has breadth at most 2. To prove the theorem, we will assume that these eight elements are a proper sublattice of  $\mathbf{L}$ , and show that  $\mathbf{L}$  contains a sublattice isomorphic to one of  $\mathbf{G}_1$ – $\mathbf{G}_8$ .

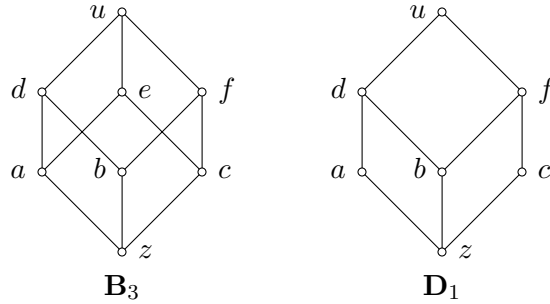

FIGURE 23.

**Case 1.** Suppose there exists  $p \in L - B$  with  $b \succ p > z$ .

(i) If  $p \vee a = d$  and  $p \vee c = f$ , then  $B \cup \{p\}$  is a sublattice of  $\mathbf{L}$  isomorphic to  $\mathbf{G}_1$ .

(ii) If  $p \vee a = d$  and  $p \vee c < f$  (or *vice versa*), then  $p \vee b = p \vee a \vee c = d \vee c = u$ . Thus  $B \cup \{p, p \vee c\}$  is a sublattice of  $\mathbf{L}$  isomorphic to  $\mathbf{G}_2$ .

(iii) If  $p \vee a < d$  and  $p \vee c < f$  and  $p \vee e = u$ , then  $\{a, b, d, f, u, z, p, p \vee a, p \vee c\}$  is a sublattice of  $\mathbf{L}$  isomorphic to  $\mathbf{G}_8$ .

(iv) If  $p \vee a < d$  and  $p \vee c < f$  and  $p \vee e < u$ , then  $p \vee e = p \vee a \vee c$  irredundantly, contrary to the assumption that  $p \vee e/z$  has breadth at most two.

So we may assume that  $b \succ z$ . Symmetrically and dually, we have  $a \succ z$ ,  $c \succ z$ ,  $u \succ d$ ,  $u \succ e$ , and  $u \succ f$ .

**Case 2.** Suppose there exists  $p \in L - B$  with  $d > p > a$ . Then, using the above coverings, we get  $\{a, b, d, e, u, z, p\} \cong \mathbf{G}_7 \leq \mathbf{L}$ .

Thus we may assume that  $d \succ a$ . Symmetrically  $d \succ b$ ,  $e \succ a$ ,  $e \succ c$ ,  $f \succ b$  and  $f \succ c$ . Thus  $\mathbf{B}$  is a covering sublattice of  $\mathbf{L}$ .

**Case 3.** Suppose there exists  $t \in L - B$  with  $t < a$  and  $t \parallel z$ . Then, using  $a \succ z$ , we have that  $B \cup \{t, t \wedge z\} \cong \mathbf{G}_3 \leq \mathbf{L}$ .

So we may assume that for all  $t \in L - B$ ,  $t \not\leq a$  implies  $t \wedge a \leq z$ , and symmetrically and dually.

**Case 4.** Suppose there exists  $t \in L - B$  with  $t < d$  and  $t \not\leq z$ .

(i) If  $d > t > z$ , then using the coverings we have  $\{t, a, b, d, z\} \cong \mathbf{M}_3 = \mathbf{G}_5 \leq \mathbf{L}$ .

(ii) If  $d > t \not\leq z$ , then we may assume that  $z \vee t = d$ , for otherwise  $d > z \vee t > z$ , which reduces to Case 4(i). (Note that  $z \vee t \neq a, b$  or  $c$  by Case 3.) Since  $a \wedge t \leq z$  and  $b \wedge t \leq z$ , we have  $a \wedge t = z \wedge t = b \wedge t$ . Together with  $z \vee t = d$  this implies  $\{t, a, b, d, z, z \wedge t\} \cong \mathbf{G}_6^d \leq \mathbf{L}$ .

Thus we may assume that for all  $t \in L - B$ , either  $t > d$  or  $t \wedge d \leq z$ , and symmetrically for  $e$  and  $f$ . Dually, for all  $t \in L - B$ , either  $t < a$  or  $t \vee a \geq u$ , and symmetrically.

Because  $\mathbf{L}$  is linearly indecomposable and  $\mathbf{B} < \mathbf{L}$ , there exists an element  $v \in L - B$  such that  $v \not\leq z$  and  $v \not\leq u$ . If  $v < a$ , then Case 3 yields  $v = v \wedge a \leq z$ , a contradiction. Hence by Case 4 we have  $v \vee a \geq u$ . Symmetrically,  $v \vee b \geq u$  and  $v \vee c \geq u$ . Thus  $v \vee a = v \vee b = v \vee c = v \vee u$ , and dually  $v \wedge d = v \wedge e = v \wedge f = v \wedge z$ .

If  $z < v < u$ , then  $\{v, a, f, u, z\}$  is a sublattice of  $\mathbf{L}$  isomorphic to  $\mathbf{M}_3 = \mathbf{G}_5$ .

If  $z < v \not\leq u$ , then we may assume that  $u \wedge v = z$ , for otherwise  $z < u \wedge v < u$ , which is the previous situation. But if  $u \wedge v = z$ , then  $\{v, a, f, u, z, u \vee v\}$  is a sublattice of  $\mathbf{L}$  isomorphic to the dual of  $\mathbf{G}_6^d$ .

The case  $z \not\leq v < u$  is dual.

If  $z \not\leq v$  and  $v \not\leq u$ , then we may assume that  $v \vee z > u$ , or else we have  $z < v \vee z \not\leq u$ , a previous situation. Likewise, we may assume that  $v \wedge u < z$ . But then  $B \cup \{v, v \vee u, v \wedge z\}$  is a sublattice of  $\mathbf{L}$  isomorphic to  $\mathbf{G}_4$ .  $\square$

## 8. REDUCTION TO SEMIDISTRIBUTIVE LATTICES

In this section we will show how to decide whether a finite, linearly indecomposable, breadth 2 lattice which fails the meet semidistributive law  $\text{SD}_\wedge$  is small. Dual considerations apply to those lattices which fail to be join semidistributive. Thus when we have finished this section it will remain to consider only linearly indecomposable, breadth 2, semidistributive lattices.

**Theorem 31.** *If  $\mathbf{L}$  is a finite, linearly indecomposable lattice with  $\text{br}(\mathbf{L}) = 2$ , and  $\mathbf{L}$  does not satisfy  $\text{SD}_\wedge$ , then  $\mathbf{L}$  is big unless  $\mathbf{L}$  contains a sublattice  $\{a, b, c, d, f, u, z\}$  isomorphic to  $\mathbf{D}_1$  (as labelled in Figure 23) such that*



1.  $L = D_1 \cup 1/d \cup 1/f$  (so  $z = 0$ ),
2.  $\mathbf{L} - \{a\}$  and  $\mathbf{L} - \{c\}$  are small lattices satisfying  $SD_\wedge$ ,
3.  $a$  and  $c$  are join prime,
4.  $\mathbf{FQ}(a, \kappa(a))$  and  $\mathbf{FQ}(c, \kappa(c))$  are finite.

If  $\mathbf{L}$  satisfies conditions 1–4, then it is small.

*Proof.* Assume first that  $\mathbf{L}$  is finite, linearly indecomposable, breadth 2, and fails  $SD_\wedge$ . We want to show that if  $\mathbf{L}$  does not satisfy (1)–(4), then it is big.

A finite lattice which fails  $SD_\wedge$  contains one of  $\mathbf{G}_5$ ,  $\mathbf{G}_6$ ,  $\mathbf{G}_6^d$ ,  $\mathbf{G}_7$ , or  $\mathbf{D}_1$  as a sublattice [7], cf. [9], p. 207. Since the first four of these lattices are big, if  $\mathbf{L}$  contains one of them then it is big. Thus we can assume that  $\mathbf{L}$  contains a sublattice  $\{a, b, c, d, f, u, z\}$  isomorphic to  $\mathbf{D}_1$ . Moreover, we can choose this sublattice so that every proper subinterval of  $u/z$  satisfies  $SD_\wedge$ .

**Claim 1.** If  $b \not\succeq z$ , then  $\mathbf{L}$  is big. For suppose there exists  $p \in L - D_1$  with  $b \succ p \succ z$ .

(i) If  $p \vee a = d$  and  $p \vee c = f$ , then  $D_1 \cup \{p\} \cong \mathbf{G}_9 \leq \mathbf{L}$ .

(ii) If  $p \vee a = d$  and  $p \vee c < f$ , then  $D_1 \cup \{p, p \vee c\} \cong \mathbf{G}_{10} \leq \mathbf{L}$ . The case  $p \vee a < d$  and  $p \vee c = f$  is symmetric.

(iii) If  $p \vee a < d$  and  $p \vee c < f$ , then  $\{p, p \vee a, b, p \vee c, d, f, u\}$  is a sublattice of  $\mathbf{L}$  isomorphic to  $\mathbf{D}_1$ , which violates the minimality of the interval  $u/z$ .

So we may assume that  $b \succ z$ .

**Claim 2.** If  $d \not\succeq a$ , then  $\mathbf{L}$  is big. For suppose  $d > p > a$ . As  $b \succ z$ , we get  $b \wedge p = 0$ , and hence  $D_1 \cup \{p\} \cong \mathbf{G}_{11} \leq \mathbf{L}$ .

Thus we may assume that  $d \succ a$ , and symmetrically  $f \succ c$ .

**Claim 3.** If  $a \not\succeq z$ , then  $\mathbf{L}$  is big. For suppose  $a \succ p \succ z$ . If  $c \vee p < u$ , then we claim that  $c \vee p \not\leq f$ . For if  $f < c \vee p < u$ , then we can apply  $SD_\wedge$  in the interval  $c \vee p/z$ , using  $b \succ z$ , as follows:

$$z = b \wedge c = b \wedge p \text{ implies } z = b \wedge (c \vee p)$$

whereas  $b \leq f \leq c \vee p$ , a contradiction. We conclude that either  $c \vee p = u$  or  $c \vee p \not\leq f$ .

(i) Suppose  $b \vee p < d$  and  $c \vee p \not\leq f$ . If  $(b \vee p) \wedge (c \vee p) = p$ , then using  $SD_\wedge$  in the interval  $u/p$  we get

$$\begin{aligned} p &= (b \vee p) \wedge (c \vee p) = (b \vee p) \wedge a \\ &= (b \vee p) \wedge (a \vee c \vee p) = (b \vee p) \wedge u = b \vee p \end{aligned}$$

a contradiction. Thus  $p < (b \vee p) \wedge (c \vee p) < b \vee p$ . Using  $d \succ a \succ p$  and  $b \succ z$ , we see that  $\{d, a, b \vee p, (b \vee p) \wedge (c \vee p), p, b, z\}$  is a sublattice of  $\mathbf{L}$  isomorphic to  $\mathbf{G}_7$ .

(ii) Suppose  $b \vee p = d$  and  $c \vee p \not\leq f$ . Using  $SD_\wedge$  in the interval  $d/z$ , we see that

$$\begin{aligned} z &= b \wedge a = b \wedge [d \wedge (c \vee p)] \\ &= b \wedge (a \vee (d \wedge (c \vee p))) \end{aligned}$$

whence, as  $d \succ a$ , we have  $d \wedge (c \vee p) \leq a$  and thus  $d \wedge (c \vee p) = a \wedge (c \vee p) = p$ . It follows that  $\{u, c \vee p, d, a, p, b, z\}$  is a sublattice of  $\mathbf{L}$  isomorphic to  $\mathbf{G}_7$ .

(iii) If  $b \vee p < d$  and  $c \vee p = u$ , then  $\{u, d, f, a, p, b \vee p, b, c, z\}$  is a sublattice of  $\mathbf{L}$  isomorphic to  $\mathbf{G}_{12}$ .

(iv) Finally, if  $b \vee p = d$  and  $c \vee p = u$ , then  $D_1 \cup \{p\} \cong \mathbf{G}_{11} \leq \mathbf{L}$ .

We conclude that  $\mathbf{L}$  is big unless  $a \succ z$ , and symmetrically  $c \succ z$ .

**Claim 4.** If  $d \not\succeq b$ , then  $\mathbf{L}$  is big. For suppose  $d \succ p > b$ . Then  $p \vee f < u$ , for otherwise  $\{u, d, a, p, f, b, z\}$  is a sublattice of  $\mathbf{L}$  isomorphic to  $\mathbf{G}_7$ . But then  $D_1 \cup \{p, p \vee f\}$  is a sublattice isomorphic to  $\mathbf{G}_{10}$ .

We conclude that  $d \succ b$ , and symmetrically  $f \succ b$ . Thus most of the covers in  $\mathbf{D}_1$  are covers in  $\mathbf{L}$ , except we may not have  $u \succ f$  or  $u \succ d$ .

**Claim 5.** If there exists  $t \in L - D_1$  such that  $t < a$  and  $t \parallel z$ , then  $D_1 \cup \{t, t \wedge z\} \cong \mathbf{G}_8 \leq \mathbf{L}$ . The same conclusion holds if  $t < c$  and  $t \parallel z$ .

If there exists  $t \in L - D_1$  such that  $t < b$  and  $t \parallel z$ , then  $D_1 \cup \{t, t \wedge z\} \cong \mathbf{G}_{13} \leq \mathbf{L}$ .

We conclude that  $t \not\leq a$  implies  $t \wedge a \leq z$ , and similarly for  $b$  and  $c$ .

**Claim 6.** Suppose there exists  $t \in L - D_1$  with  $t < d$  and  $t \not\leq z$ .

(i) If  $t > z$  then  $\{t, a, b, d, z\}$  is a sublattice of  $\mathbf{L}$  isomorphic to  $\mathbf{M}_3 = \mathbf{G}_5$ .

(ii) If  $t \parallel z$ , then we may assume that  $t \vee z = d$ , or else revert to part (i).

By Claim 5 we have  $a \wedge t = z \wedge t = b \wedge t$ . Thus  $\{t, a, b, d, z, z \wedge t\}$  is a sublattice of  $\mathbf{L}$  isomorphic to  $\mathbf{G}_6^d$ .

So for  $t \in L - D_1$ ,  $t < d$  implies  $t < z$ . Symmetrically,  $t < f$  implies  $t < z$ .

**Claim 7.** Now suppose there exists  $t \in L - D_1$  with  $t < u$  and  $t \not\leq z$ . We want to show that  $t \geq d$  or  $t \geq f$ , so assume that both of these fail.

(i) If  $t > b$ , then, using  $\text{SD}_\wedge$  in the interval  $u/b$  and the covering relations, we obtain

$$b = d \wedge t = f \wedge t = (d \vee f) \wedge t = u \wedge t = t$$

a contradiction.

Thus we may assume that  $b \vee t \geq d$  or  $f$ , say the former. It follows that  $f \vee t = u$ .

(ii) If  $t > a$ , then  $z = c \wedge b = c \wedge t$ , whence either  $b \vee t = u$  or  $c \wedge (b \vee t) = z$ . In the former case  $\{u, t, d, t \wedge d, c, z\} \cong \mathbf{G}_6^d \leq \mathbf{L}$ , while in the latter case  $\{u, b \vee t, t, d, t \wedge d, b, c, z\} \cong \mathbf{G}_{12} \leq \mathbf{L}$ .

Thus we may assume that  $a \vee t \geq d$  (as  $a \vee t \geq f$  implies  $a \vee t = u \geq d$ ).

Symmetrically,  $t > c$  implies  $\{u, t, f, t \wedge f, a, z\}$  is a sublattice isomorphic to  $\mathbf{G}_6^d$ , so we may assume that  $c \vee t \geq f$  and hence  $c \vee t = u$ .

(iii) If  $t > z$  and  $t \not\leq a, b$  or  $c$ , then by Claim 6 we may assume that  $d \wedge t = z = f \wedge t$ . But then  $z = a \wedge t = a \wedge b < a \wedge (b \vee t)$ , whence  $b \vee t = u$ . This makes  $\{t, a, f, u, z\} \cong \mathbf{M}_3 = \mathbf{G}_5 \leq \mathbf{L}$ .

(iv) If  $t \not\leq z$ , then either  $b \vee t = u$  and  $\{t, a, f, u, z, t \wedge z\} \cong \mathbf{G}_6^d \leq \mathbf{L}$ , or  $b \vee t < u$  and  $\{t \wedge z, b, d, f, t, b \vee t, u\} \cong \mathbf{G}_7 \leq \mathbf{L}$ .

Thus in each case  $\mathbf{L}$  is big, so we can assume that for  $t \in L - D_1$ ,  $t < u$  implies  $t > d$  or  $t > f$  or  $t < z$ .

Now we want to show that if there is an element  $t \in L - D_1$  with  $t \not\leq d$ ,  $t \not\leq f$  and  $t \not\leq z$ , then  $\mathbf{L}$  is big. Together with linear indecomposability, this implies that if  $\mathbf{L}$  is small then condition (1) of the theorem holds. So

assume that  $t$  is such an element, and note that by Claim 7 we have either  $u \wedge t \in D_1$  or  $u \wedge t < z$ .

As  $\text{br}(\mathbf{L}) = 2$ , we may assume that  $t \vee u = t \vee a \vee c = t \vee c$ , say. Thus  $t \not\leq c$ .

(i) Suppose  $u \wedge t = a$ . If  $t \vee d > u$ , then  $\{t, a, z, d, c, u, t \vee u\}$  is a sublattice of  $\mathbf{L}$  isomorphic to  $\mathbf{G}_7$ . If  $t \vee d \not\leq u$  and  $u \wedge (t \vee d) = d$ , then  $D \cup \{t, t \vee d, t \vee u\}$  is a sublattice of  $\mathbf{L}$  isomorphic to  $\mathbf{G}_{14}$ . But if  $t \vee d \not\leq u$  and  $u \wedge (t \vee d) > d$ , then  $D \cup \{t, t \vee d, u \wedge (t \vee d), t \vee u\}$  is a sublattice of  $\mathbf{L}$  isomorphic to  $\mathbf{G}_{15}$ .

(ii) Suppose  $u \wedge t = b$ . If  $t \vee d = t \vee u$ , then  $\{b, d, f, u, t, t \vee u\}$  is a sublattice of  $\mathbf{L}$  isomorphic to the dual of  $\mathbf{G}_6^d$ . If  $t \vee d < t \vee u$ , then  $\{z, b, c, u \wedge (t \vee d), f, u, t, t \vee d, t \vee u\}$  is a sublattice of  $\mathbf{L}$  isomorphic to  $\mathbf{G}_8$ , regardless of whether or not  $u \wedge (t \vee d) = d$ .

(iii) Suppose  $u \wedge t = z$ . We can assume that  $a \vee t > d$ , or else we revert to (i). Likewise  $b \vee t > d$  or  $f$ , and in the latter case  $b \vee t = u \vee t = d \vee t$  also holds, because  $f \geq c$  and  $c \vee t \geq u$ . So, regardless of whether  $d \vee t < u \vee t$  or  $d \vee t = u \vee t$ , then  $\{z, t, a, b, d, d \vee t\}$  is a sublattice of  $\mathbf{L}$  isomorphic to the dual of  $\mathbf{G}_6$ .

(iv) Suppose  $u \wedge t < z$ . By (iii) we can assume that  $z \vee t > d$ . If  $d \vee t < u \vee t$  and  $u \wedge (d \vee t) = d$ , then  $D_1 \cup \{z \wedge t, t, d \vee t, u \vee t\}$  is a sublattice of  $\mathbf{L}$  isomorphic to  $\mathbf{G}_{16}$ . If  $d \vee t < u \vee t$  and  $u \wedge (d \vee t) > d$ , then  $D_1 - \{a\} \cup \{z \wedge t, t, d \vee t, u \wedge (d \vee t), u \vee t\}$  is a sublattice of  $\mathbf{L}$  isomorphic to  $\mathbf{G}_{65}^d$ . Finally,  $d \vee t = u \vee t$  yields  $D_1 \cup \{z \wedge t, t, u \vee t\} \cong \mathbf{G}_{17} \leq \mathbf{L}$ .

We conclude from this argument that  $\mathbf{L}$  is big unless  $L = D_1 \cup 1/d \cup 1/f \cup z/0$ . Since  $\mathbf{L}$  is linearly indecomposable, we must have  $z = 0$ , and this proves condition (1) of the theorem.

The sublattices  $\mathbf{L} - \{a\}$  and  $\mathbf{L} - \{c\}$  are small if  $\mathbf{L}$  is. They are linearly indecomposable, and neither can they contain a sublattice isomorphic to  $\mathbf{D}_1$  with  $z = 0$ . Hence if  $\mathbf{L}$  is small, then they must satisfy  $\text{SD}_\wedge$ . This proves (2).

Let us show that  $a$  is join prime if  $\mathbf{L}$  is small. Suppose say that  $a < x \vee y$  properly. Because  $L = D_1 \cup 1/d \cup 1/f$ , we must have  $x, y > f$ . As  $x \vee y \geq a \vee f = u$ , we can calculate

$$b = d \wedge x = d \wedge y < d \wedge (x \vee y) = d.$$

Thus one of the five minimal lattices witnessing the failure of  $\text{SD}_\wedge$  occurs as a sublattice of  $1/b$ . A sublattice isomorphic to  $\mathbf{G}_5$ ,  $\mathbf{G}_6$ ,  $\mathbf{G}_6^d$  or  $\mathbf{G}_7$  makes  $\mathbf{L}$  big immediately, and so does a sublattice isomorphic to  $\mathbf{D}_1$  with  $z > 0$ . This proves (3).

Finally, if  $\mathbf{L}$  is small, then  $\mathbf{FQ}(a, \kappa(a))$  and  $\mathbf{FQ}(c, \kappa(c))$  must be finite by Theorem 26, which is (4).

Now assume that  $\mathbf{L}$  satisfies (1)–(4) and that  $\mathbf{L} \prec \mathbf{K}$ . We want to show that  $\mathbf{K}$  is finite.

Let  $k = \kappa(a)$  and  $l = \kappa(c)$ . Note that, by  $\text{SD}_\wedge$ ,

$$\begin{aligned} b &= k \wedge d = l \wedge f \\ &= k \wedge l \wedge u. \end{aligned}$$

Since  $\text{br}(\mathbf{L}) = 2$ , this implies  $k \wedge l = b$ .

**Lemma 32.** *Let  $\mathbf{L}$ ,  $\mathbf{S}$  and  $\mathbf{T}$  be sublattices of a lattice  $\mathbf{K}$ , and let  $F$  be a subset of  $K$ , satisfying the following properties.*

1.  $\mathbf{S} < \mathbf{L} < \mathbf{K}$  and  $\mathbf{S} < \mathbf{T}$ .
2.  $S \cup F = L$  and  $T \cap F = \emptyset$ .
3. For every  $q \in T - S$ ,  $F \cup \text{Sg}(\{q\} \cup S)$  is a sublattice of  $\mathbf{K}$ .

Then  $\mathbf{S} < \mathbf{T}$  and  $T \cup F = K$ , whence  $|K - L| = |T - S|$ .

*Proof.* Let  $q \in T - S$ . Then  $q \notin S \cup F = L$ , so  $\mathbf{L} < F \cup \text{Sg}(\{q\} \cup S) \leq \mathbf{K}$ , whence  $F \cup \text{Sg}(\{q\} \cup S) = K$ . For any other element  $p \in T - S$ , we have  $p \notin F$  so  $p \in \text{Sg}(\{q\} \cup S)$ . Thus  $\text{Sg}(\{q\} \cup S) = \mathbf{T}$ .  $\square$

**Claim 1:** We may assume that in  $\mathbf{K}$ ,  $l/d \cup k/f \cup 1/u \subseteq L$ . For suppose that  $p \in K - L$  and that  $p$  is in one of these intervals. Then we can prove the following, using  $\mathbf{K} = \text{Sg}(L \cup \{p\})$  and the closure of these properties under join and meet.

1. For all  $w \in K$ , either  $w \geq a$  or  $w \leq k$ .
2. For all  $w \in K$ , either  $w \geq c$  or  $w \leq l$ .
3. For all  $w \in K$ , either  $w \geq b$  or  $w \in \{0, a, c\}$ .

Now apply Lemma 32 with

$$\begin{aligned} \mathbf{S} &= \mathbf{L} - \{0, a, c\} \\ \mathbf{T} &= \text{Sg}(\{p\} \cup S) \\ F &= \{0, a, c\}. \end{aligned}$$

The properties above are used to verify the conditions of the lemma. The crucial observation is that  $w \in T$  implies  $w \geq b$ ; hence  $w \vee a = w \vee d \in T$ , and similarly  $w \vee c \in T$ . We conclude that  $\mathbf{S} < \mathbf{T}$  and  $T \cup F = K$ . Since  $\mathbf{S}$  is small by condition (3) of the theorem, and  $F$  is finite, it follows that  $\mathbf{K}$  is finite.

**Claim 2:** We may assume that in  $\mathbf{K}$ ,  $b \succ 0$ ,  $d \succ a$  and  $f \succ c$ . First suppose that there exists  $p \in K - L$  with  $b > p > 0$ . Then we can establish the following series of claims.

1. For all  $w \in K$ , either  $w \geq a$  or  $w \leq k$ .
2. For all  $w \in K$ , either  $w \geq c$  or  $w \leq l$ .
3. For all  $w \in K$ , either  $w \geq p$  or  $w \in \{0, a, c\}$ .
4.  $p$  is the only element of  $K - L$  in  $b/0$ .
5.  $L \cup \{p, p \vee a, p \vee c\} \leq \mathbf{K}$  (and hence  $= \mathbf{K}$ ).

It then follows easily that  $d \succ a$  and  $f \succ c$ , or else  $\mathbf{K}$  is finite.

**Claim 3:** If there exists  $p \in K - L$  with  $p_{[\mathbf{L}]} = a$  and  $p^{[\mathbf{L}]} \leq l$ , then  $\mathbf{K}$  is finite. For once again in this case we have  $K = l/a \cup k/c \cup 1/u \cup b/0$ , and

using Claim 1 and Claim 2 one can prove that  $q \in K - L$  implies  $q \in l/a$ . Now apply Lemma 32 with

$$\begin{aligned}\mathbf{S} &= \mathbf{L} - \{c\} \\ \mathbf{T} &= \text{Sg}(\{p\} \cup S) \\ F &= \{c\}.\end{aligned}$$

The conditions of the lemma are easily verified, and we conclude as in Claim 1 that  $\mathbf{K}$  is finite.

Thus we may assume that  $l/a \subseteq L$ , and symmetrically  $k/c \subseteq L$ .

**Claim 4:** We may assume that in  $\mathbf{K}$ ,  $a \succ 0$  and  $c \succ 0$ . Proving this claim gives us our first chance to use an argument which will recur several times. It provides, under suitable hypotheses, a sort of converse to Theorem 26. The last part of the argument (checking closure) will vary slightly in each application, but the first part is easily formulated into a lemma.

**Lemma 33.** *Let  $\mathbf{L}$  be a finite lattice which is a maximal sublattice of a lattice  $\mathbf{K}$ . Suppose there exists an element  $p \in K - L$  satisfying the following properties, where  $p^{[\mathbf{L}]} = a$  and  $p_{[\mathbf{L}]} = b$ .*

1.  $a$  is meet irreducible in  $\mathbf{L}$ .
2. There exists a unique largest element  $m \in L$  such that  $a \wedge m = b$ .
3.  $\mathbf{FQ}(a, m)$  is finite.

Let

$$\mathbf{M} = \text{Sg}_{\mathbf{K}}(\{p \vee x : x \in L \cap m/b\} \cup \{(p \vee m) \wedge y : y \in L \cap (a \vee m)/a - \{a\}\}).$$

Then  $\mathbf{M}$  is a homomorphic image of  $\mathbf{FQ}(a, m)$ , and hence finite.

*Proof.* Suppose that  $\mathbf{L}$ ,  $\mathbf{K}$  and  $p$  are as given. Then it is easy to check that the map  $h : \mathbf{Q}(a, m) \rightarrow \mathbf{M}$  defined by

$$h(q_t) = \begin{cases} p \vee t & \text{if } t \in m/b \\ (p \vee m) \wedge t & \text{if } t \in (a \vee m)/a - \{a\} \\ p & \text{if } t = a \end{cases}$$

is well defined and consistent with the defining relations of  $\mathbf{Q}(a, m)$ , as follows.

1.  $h(q_a) = p = h(q_{a \wedge m})$  and  $h(q_m) = p \vee m = h(q_{a \vee m})$ .
2. If  $s, t \in m/b$ , then  $h(q_{s \vee t}) = p \vee s \vee t = h(q_s) \vee h(q_t)$ .
3. If  $a < s, t \leq a \vee m$ , then  $a < s \wedge t$  since it is meet irreducible, and thus  $h(q_{s \wedge t}) = (p \vee m) \wedge s \wedge t = h(q_s) \wedge h(q_t)$ . Clearly  $h(q_a) = p \leq h(q_t)$  for all  $t \in (a \vee m)/a$ .
4. If  $s \in m/b$  and  $t \in (a \vee m)/a$  and  $s \leq t$ , then w.l.o.g.  $t \neq a$  and  $h(q_s) = p \vee s \leq (p \vee m) \wedge t = h(q_t)$ .

Hence  $h$  extends to a homomorphism  $h : \mathbf{FQ}(a, m) \rightarrow \mathbf{M}$ , which is surjective because the generators of  $\mathbf{M}$  are in its range. Since  $\mathbf{FQ}(a, m)$  is finite, so is  $\mathbf{M}$ .  $\square$

Now suppose say  $a > p > 0$  with  $p \in K - L$ . Applying Lemma 33 with  $m = k$ , we conclude that  $\mathbf{M}$  is finite. It remains to show that  $L \cup M$  is a sublattice of  $\mathbf{K}$ , and hence in fact equal to  $K$ . (This union need not be disjoint; in particular, if  $p \vee m \in L$ , then it won't be.)

Let  $x \in L$  and  $w \in M$ . Note that  $p \leq w \leq p \vee m$ , and that again we have, for all  $v \in K$ , either  $v \geq c$  or  $v \leq l$ . If  $x \leq k$ , then  $x \vee w = ((x \vee b) \vee p) \vee w$ , which is in  $M$  because  $(x \vee b) \vee p \in M$ . If  $x \geq a$  and either  $x$  or  $w \geq c$ , then  $x \vee w \geq u$ , whence  $x \vee w \in L$  by Claim 1. So we may assume that  $x \geq a$  and both  $x, w \leq l$ , whence  $a \leq x \vee w \leq l$ . By Claim 3, this implies  $x \vee w \in L$ . Since  $\mathbf{L}$  and  $\mathbf{M}$  are both sublattices, this shows that  $L \cup M$  is closed under joins.

Likewise, if  $x > a$  then  $x \wedge w = ((x \wedge (a \vee m)) \wedge (p \vee m)) \wedge w$ , which is in  $M$  because  $x \wedge (a \vee m) > a$  and so  $(x \wedge (a \vee m)) \wedge (p \vee m) \in M$ . If  $x = a$ , then  $p \leq x \wedge w \leq a$ , while  $p \prec a$  by Lemma 21; thus  $x \wedge w \in \{p, a\} \subseteq L \cup M$ . On the other hand, if  $x \leq k$  and either  $x$  or  $w \leq l$ , then  $x \wedge w \leq b$ , whence  $x \wedge w \in L$  by Claim 2. So we may assume that  $x \leq k$  and both  $x, w \geq c$ , whence  $c \leq x \wedge w \leq k$ . Again by Claim 3, this implies  $x \wedge w \in L$ . Thus  $L \cup M$  is closed under meets.

**Claim 5:** If there exists  $p \in K - L$  with  $p_{[\mathbf{L}]} = a$  and  $p^{[\mathbf{L}]} \geq u$ , then  $\mathbf{K}$  is finite. In this case we apply Lemma 32 with

$$\begin{aligned} \mathbf{S} &= \mathbf{L} - \{c\} \\ \mathbf{T} &= \text{Sg}(\{p\} \cup S) \\ F &= \{c\}. \end{aligned}$$

Note that for all  $w \in K$ , either  $w \geq a$  or  $w \leq k$ .

To verify that  $c \notin T$  (part of condition 2 of the lemma), we show that  $c$  is doubly irreducible in  $\mathbf{K}$ . Since  $c \succ 0$ , it is join irreducible. Suppose  $c = w_1 \wedge w_2$  in  $\mathbf{K}$ . Then  $c = c_{[\mathbf{L}]} = (w_1)_{[\mathbf{L}]} \wedge (w_2)_{[\mathbf{L}]}$  whence  $c = (w_1)_{[\mathbf{L}]}$  say. Then  $a \not\leq w_1$ , so  $w_1 \leq k$ . But by Claim 3,  $w_1 \in k/c$  implies  $w_1 \in L$ , whence  $w_1 = c$ . Thus  $c$  is meet irreducible.

To verify condition 3 of the lemma, let  $q \in T - S$  and let  $w \in \text{Sg}(\{q\} \cup S)$ . Since  $c \succ 0$  in  $\mathbf{K}$ ,  $c \wedge w \in \{0, c\}$ . If  $w \geq a$  then  $c \vee w = u \vee w \in \text{Sg}((L - \{c\}) \cup \{p\})$ . On the other hand, if  $w \leq k$  then  $c \vee w \in k/c$ , and hence  $c \vee w \in L$  by Claim 3. Thus  $\{c\} \cup \text{Sg}(\{q\} \cup S)$  is a sublattice of  $\mathbf{K}$ . As before, we conclude that  $\mathbf{K}$  is finite.

The case  $p_{[\mathbf{L}]} = c$  and  $p^{[\mathbf{L}]} \geq u$  is similar. Combining Claims 3 and 5, we see that if  $p_{[\mathbf{L}]} \in \{a, c\}$  for some  $p \in K - L$ , then  $\mathbf{K}$  is finite. Thus we may assume that  $p_{[\mathbf{L}]} \notin \{a, c\}$  for all  $p \in K - L$ .

**Claim 6:**  $\mathbf{K}$  is finite. Let  $p \in K - L$ . Again we apply Lemma 32 with

$$\begin{aligned} \mathbf{S} &= \mathbf{L} - \{c\} \\ \mathbf{T} &= \text{Sg}(\{p\} \cup S) \\ F &= \{c\}. \end{aligned}$$

To verify that  $c \notin T$ , we again show that  $c$  is doubly irreducible in  $\mathbf{K}$ . Since  $c \succ 0$ , it is join irreducible. Suppose  $c = w_1 \wedge w_2$  in  $\mathbf{K}$ . Then  $c = c_{[\mathbf{L}]} = (w_1)_{[\mathbf{L}]} \wedge (w_2)_{[\mathbf{L}]}$ , whence  $c = (w_1)_{[\mathbf{L}]}$  say. By the assumption at the end of Claim 5, this implies  $w_1 \in L$ , and hence  $w_1 = c$ . Thus  $c$  is meet irreducible.

To verify condition 3 of the lemma, let  $q \in T - S$  and let  $w \in \text{Sg}(\{q\} \cup S)$ . Since  $c \succ 0$  in  $\mathbf{K}$ ,  $c \wedge w \in \{0, c\}$ . On the other hand,  $c \vee w = (c \vee w)_{[\mathbf{L}]} \vee w \in \text{Sg}(\{q\} \cup S)$  because  $(c \vee w)_{[\mathbf{L}]} > c$  by the assumption at the end of Claim 5.

So we conclude that  $\mathbf{K}$  is finite, as desired.  $\square$

Now we can apply Theorem 31 to find all non-meet-semidistributive minimal big lattices.

**Theorem 34.** *The only minimal big lattices which fail  $\text{SD}_\wedge$  are  $\mathbf{G}_5$ ,  $\mathbf{G}_6$ ,  $\mathbf{G}_6^d$ ,  $\mathbf{G}_7$ ,  $\mathbf{G}_8$ , and  $\mathbf{G}_i$  with  $9 \leq i \leq 19$ .*

*Proof.* Let  $\mathbf{L}$  be a minimal big lattice which fails  $\text{SD}_\wedge$ . If  $\mathbf{L}$  is not isomorphic to  $\mathbf{G}_5$ ,  $\mathbf{G}_6$ ,  $\mathbf{G}_6^d$  or  $\mathbf{G}_7$ , then  $\mathbf{L}$  contains a copy of  $\mathbf{D}_1$  and fails one of the conditions (1)–(4) of the previous theorem. The first half of the preceding proof shows that if  $\mathbf{L}$  fails (1), (2) or (3), then  $\mathbf{K}$  contains a sublattice isomorphic to some  $\mathbf{G}_i$  with  $8 \leq i \leq 17$ .

It remains to consider minimal big lattices which satisfy (1)–(3), but fail condition (4). Assume that  $\mathbf{L}$  is such a lattice.

First, we claim that in  $\mathbf{L}$  the interval  $u/d$  is a chain. For if  $s$  and  $t$  were incomparable elements in  $u/d$ , then  $s \vee t < u$  by condition (3), and  $\{u, s \vee t, s, t, s \wedge t, f, b, c, z\}$  would be a sublattice of  $\mathbf{L}$  isomorphic to  $\mathbf{G}_{24}^d$ , contradicting the minimality of  $\mathbf{L}$ . Symmetrically,  $u/f$  is also a chain.

Moreover, either  $u \succ d$  or  $u \succ f$  or  $|u/d| = |u/f| = 3$ . For otherwise, we would have say  $|u/d| > 3$  and  $|u/f| \geq 3$ . Then  $u/d$  would contain a 4 element chain  $u > g > h > d$  say, while  $u > m > f$ . Then  $D_1 \cup \{g, h, m\} - \{a\} \cong \mathbf{G}_{46}$ , contradicting (2).

Next, suppose  $|u/d| = |u/f| = 3$ , say  $u \succ h \succ d$  and  $u \succ m \succ f$ . If  $L = D_1 \cup \{h, m\}$ , then it is straightforward to check that  $|\mathbf{FQ}(a, m)| = |\mathbf{FQ}(c, h)| = 22$ , whence  $\mathbf{L}$  satisfies (4) and is not big. But if  $\mathbf{L}$  is properly larger than that, then by (1) and (3) there is an element  $t$  with say  $m < t < u \vee t$ . Then  $D_1 \cup \{h, m, t, u \vee t\} - \{c\} \cong \mathbf{G}_{49}$ , again contradicting (2).

Thus we may assume that  $u \succ d$  in  $\mathbf{L}$ , the case  $u \prec f$  being symmetric. Let  $k = \kappa(a)$  and  $l = \kappa(c)$ . We will show that  $\mathbf{F} = \mathbf{FQ}(a, k)$  is finite.

We claim that for all  $w \in F$ , either

- i.  $w \in \{q_z, q_b, q_c, q_d \wedge q_c, q_b \wedge q_c, q_b \vee (q_d \wedge q_c)\}$ , or
- ii.  $w \in \text{Sg}_{\mathbf{F}}(Q(a, k) - \{q_c\})$  and  $w \geq q_d \wedge q_f$ .

It is required to show that the set of elements satisfying (i) or (ii) contains the generators of  $\mathbf{F}$  and is closed under meet and join. The argument is illustrated in Figure 24. The only non-elementary calculation involves  $q_c \wedge w$  where  $w$  satisfies (ii). Note that (again by induction), for all  $u \in F$ , either

$u \geq q_c$  or  $u \leq q_{k^* \wedge l}$ . So if  $w \not\geq q_c$ , then  $q_d \wedge q_f \leq w \leq q_{k^* \wedge l}$ , whence

$$q_d \wedge q_c \leq w \wedge q_c \leq q_{k^* \wedge l} \wedge q_c = q_{k^* \wedge l} \wedge q_u \wedge q_c = q_d \wedge q_c$$

and  $w \wedge q_c = q_d \wedge q_c$ .

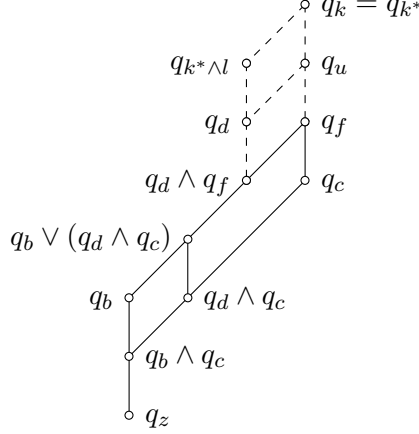

FIGURE 24.

It follows that  $\text{Sg}_{\mathbf{F}}(Q(a, k) - \{q_c\}) \cup \{q_c, q_d \wedge q_c, q_b \wedge q_c, q_b \vee (q_d \wedge q_c)\}$  is a sublattice of  $\mathbf{F}$ , and hence equal to  $\mathbf{F}$ . Therefore  $\mathbf{F}$  is finite if and only if  $\text{Sg}_{\mathbf{F}}(Q(a, k) - \{q_c\})$  is finite. However, it is clear that  $\text{Sg}_{\mathbf{F}}(Q(a, k) - \{q_c\})$  is a homomorphic image of  $\mathbf{FL}(\mathbf{Q}(a, k) - \{q_c\})$ , and the latter is finite by Theorem 26 since  $\mathbf{L} - \{c\}$  is small. Hence  $\mathbf{F}$  is finite, as claimed.

That leaves us to consider when  $\mathbf{H} = \mathbf{FQ}(c, l)$  will be infinite. If  $u \succ f$ , then an argument symmetric to the preceding one would make  $\mathbf{H}$  finite, and  $\mathbf{L}$  not big, contrary to assumption.

Next suppose  $|u/f| = 3$ , with say  $u \succ h \succ f$ . We want to use an expanded version of the preceding argument to show that  $\mathbf{H}$  would again be finite.

First, we need to show that  $l \geq d$ . For if  $l \succ n > d$ , then either  $u \vee n = u \vee l$ , in which case  $\{u \vee l, u, h, f, c, l, n, b, d, z\} \cong \mathbf{G}_{50}^d \leq \mathbf{L} - \{a\}$ , a contradiction, or  $u \vee n < u \vee l$ , in which case  $\{u \vee l, u \vee n, u, h, f, c, l, n, b, d, z\} \cong \mathbf{G}_{51}^d \leq \mathbf{L} - \{a\}$ , another contradiction.

The case  $l = d$  is easy, and yields  $|\mathbf{FQ}(c, d)| = 12$ , contrary to assumption. So w.l.o.g.  $l \succ d$ .

We claim that for all  $w \in H$ , either

- i.  $w \in \{q_z, q_b, q_f, q_d \wedge q_f, q_a, q_a \wedge q_b, q_a \wedge q_f, q_a \wedge q_h, q_b \vee (q_a \wedge q_f), q_b \vee (q_a \wedge q_h), q_f \vee (q_a \wedge q_b), (q_d \wedge q_f) \vee (q_a \wedge q_h), q_f \wedge (q_b \vee (q_a \wedge q_h)), q_d \wedge (q_f \vee (q_a \wedge q_h))\}$ ,  
or
- ii.  $w \in \text{Sg}_{\mathbf{H}}(Q(c, l) - \{q_a\})$  and  $w \geq q_d \wedge q_h$ .

Again we must show that the set of elements satisfying (i) or (ii) contains the generators of  $\mathbf{H}$  and is closed under meet and join. The argument is illustrated in Figure 25. The non-elementary calculations involve  $q_a \wedge w$  and



$(q_f \vee (q_a \wedge q_h)) \wedge w$  where  $w$  satisfies (ii). For the first of these, we use the fact that for all  $u \in H$ , either  $u \geq q_a$  or  $u \leq q_{k \wedge l^*}$ , to show that  $q_a \wedge w$  is either  $q_a$  or  $q_a \wedge q_h$ , similar to before. For the second, we observe that for all  $u \in H$ , either  $u \geq q_f$  or  $u \leq q_d$  (using  $l \succ d$ ). If  $w \geq q_f$  then  $w \geq q_f \vee (q_d \wedge q_h) \geq q_f \vee (q_a \wedge q_h)$ , while if  $w \leq q_d$  then  $q_d \wedge q_h \leq w \leq q_d$  implies  $w \wedge (q_f \vee (q_a \wedge q_h)) = q_d \wedge (q_f \vee (q_a \wedge q_h))$ .

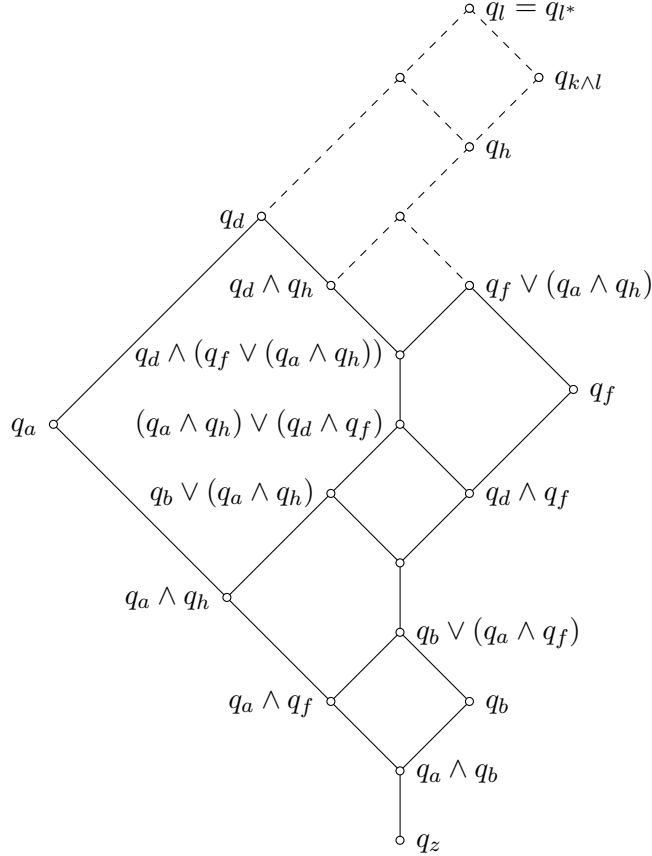

FIGURE 25.

It follows that  $\text{Sg}_{\mathbf{H}}(Q(c, l) - \{q_a\}) \cup \{q_a, q_a \wedge q_b, q_a \wedge q_f, q_a \wedge q_h, q_b \vee (q_a \wedge q_f), q_b \vee (q_a \wedge q_h), q_f \vee (q_a \wedge q_b), (q_d \wedge q_f) \vee (q_a \wedge q_h), q_f \wedge (q_b \vee (q_a \wedge q_h)), q_d \wedge (q_f \vee (q_a \wedge q_h))\}$  is a sublattice of  $\mathbf{H}$ , and hence equal to  $\mathbf{H}$ . However,  $\text{Sg}_{\mathbf{H}}(Q(c, l) - \{q_a\})$  is a homomorphic image of  $\mathbf{FL}(\mathbf{Q}(c, l) - \{q_a\})$ , and the latter is finite since  $\mathbf{L} - \{a\}$  is small. Hence  $\mathbf{H}$  is finite, as claimed. We conclude that  $|u/f| > 3$ .

Let  $u > h > m > f$ . If perchance  $\kappa(c) = l > d$ , then  $D_1 \cup \{h, m, l, l \vee u\}$  is a sublattice of  $\mathbf{L}$  isomorphic to  $\mathbf{G}_{18}$ . Thus we may assume that  $d = \kappa(c)$ . In that case the sublattice which determines  $\mathbf{Q}(c, d)$  is  $u/c \cup d/0 = D_1 \cup u/f$ .

If  $|u/f| = 4$  then  $|\mathbf{FQ}(c, d)| = 24$ , and  $\mathbf{L}$  would be small, while if  $|u/f| \geq 5$  then  $\mathbf{G}_{19} \leq \mathbf{L}$ , and that is big.

This completes the proof of the theorem.  $\square$

## 9. DOUBLY PRIME UNITS

In this section we will be concerned with showing that certain finite, breadth 2, semidistributive lattices are big.

**Definition.** A subset  $E$  of a finite lattice  $\mathbf{L}$  is a *join prime unit* if

1.  $E = \{e_0, \dots, e_k\}$  with  $k \geq 0$  and  $e_0 \prec e_1 \prec \dots \prec e_k$ .
2.  $e_0$  is join prime.
3.  $e_j$  is doubly irreducible for  $0 \leq j < k$ .
4.  $e_k$  is join irreducible.

So with every join prime element  $p$  we can associate a maximal join prime unit  $E(p)$ . Note that in  $E(p)$ , either  $e_k$  is meet reducible or  $e_k^*$  is join reducible.

**Definition.** A join prime unit is *doubly prime* if also

5.  $e_k$  is meet prime.

Recall that in a lattice satisfying  $\text{SD}_\vee$ , the canonical joinands of 1 are join prime.

**Theorem 35.** *Let  $\mathbf{L}$  be a finite, linearly indecomposable, breadth 2, semidistributive lattice with  $1_{\mathbf{L}} = p \vee r$  canonically, and let  $E(p)$  and  $E(r)$  denote their respective join prime units. If neither  $E(p)$  nor  $E(r)$  is doubly prime, then  $\mathbf{L}$  is big.*

The proof of Theorem 35 can be simplified along the following lines. Let  $\mathbf{L}$  be as in the theorem and  $1_{\mathbf{L}} = p \vee r$  canonically. Let  $E(p) = \{e_0, \dots, e_k\}$ , where of course  $e_0 = p$ , and let  $\mathbf{S}$  be the sublattice  $\mathbf{L} - \{e_0, \dots, e_{k-1}\}$ . Note that  $e_k$  is a canonical joinand of 1 in  $\mathbf{S}$ , and that  $E(p)$  is a doubly prime unit of  $\mathbf{L}$  if and only if  $\{e_k\}$  is a doubly prime unit of  $\mathbf{S}$ . Moreover, if  $\mathbf{S}$  is big, then so is  $\mathbf{L}$ . Hence we can assume that  $E(p) = \{p\}$ , and similarly  $E(r) = \{r\}$ . (This reduction applies only to the proof of Theorem 35, because we are trying to show that lattices without a doubly prime unit are big; it does not apply to the next section.)

The assumption that  $E(p) = \{p\}$  means that either  $p$  is meet reducible, or  $p$  is meet irreducible and  $p^*$  is join reducible. The proof will divide into cases according to which of these properties hold for  $p$  and  $r$ . The next lemma gives more information about the case when  $p^*$  is join reducible.

**Lemma 36.** *Let  $p$  be a join prime element in a finite lattice  $\mathbf{L}$  with  $E(p) = \{p\}$ . If  $p$  is meet irreducible, then  $p^* = p \vee (p^* \wedge \kappa(p))$  properly.*

*Proof.* If  $p$  is meet irreducible, then  $p^*$  is join reducible, say  $p^* = x \vee y$  properly. One of these elements, say  $x$ , is incomparable with  $p$ . Thus  $x \leq p^* \wedge \kappa(p)$ , so  $p^* \wedge \kappa(p) \not\leq p$ . Since  $p^* \succ p$ , this implies  $p^* = p \vee (p^* \wedge \kappa(p))$ .  $\square$

Throughout the rest of this section, we will let  $k = \kappa(p)$  and  $l = \kappa(r)$ . Note that these are coatoms of  $\mathbf{L}$ .

**Lemma 37.** *Let  $\mathbf{L}$  be a finite, breadth 2, semidistributive lattice. If  $p$  is join irreducible and  $p = p_1 \wedge p_2$ , then either  $p_1 \wedge \kappa(p) = p_*$  or  $p_2 \wedge \kappa(p) = p_*$ .*

*Proof.* Use the breadth 2 property on  $p_* = p_1 \wedge p_2 \wedge \kappa(p)$ .  $\square$

**Lemma 38.** *Let  $\mathbf{L}$  be a finite semidistributive lattice which contains elements  $p, r, p_1, p_2$  such that*

1.  $1_{\mathbf{L}} = p \vee r$  canonically,
2.  $p = p_1 \wedge p_2$  canonically,
3.  $p_1 \wedge \kappa(p) = p_*$ ,
4.  $p_* \vee r < \kappa(p)$ .

*Then  $\mathbf{L}$  contains a sublattice isomorphic to one of the big lattices  $\mathbf{G}_{20}$ ,  $\mathbf{G}_{21}$ ,  $\mathbf{G}_{22}$ , or  $\mathbf{G}_{23}$ . Hence  $\mathbf{L}$  is big.*

*Proof.* With  $k = \kappa(p)$  and  $l = \kappa(r)$  as usual, choose  $r'$  such that  $p_* \vee r \leq r' < k$ , and let  $\mathbf{S} = \text{Sg}(\{p_1, p_2, r', k\})$ . Note that for all  $w \in \mathbf{S}$  we have  $w \geq r'$  or  $w \leq p_1 \vee p_2$  exclusively, since  $p_1 \vee p_2 \leq l$ . Hence  $1 = p \vee r'$  canonically in  $\mathbf{S}$ , and dropping the prime we may as well assume that  $p_* < r < k$ .

Next choose  $p'_1$  such that  $p < p'_1 \leq p_1$ , and note that  $p_2 < p'_1 \vee p_2$  since  $p_2$  is a canonical meetand of  $p$ . We claim that  $k \wedge (p'_1 \vee p_2) \leq p_2$ , for otherwise  $\text{SD}_{\vee}$  would yield  $p'_1 \vee p_2 = (k \wedge (p'_1 \vee p_2)) \vee p_2 = (p'_1 \wedge k) \vee p_2 = p_2$ , a contradiction. Thus

$$\begin{aligned} k \wedge (p'_1 \vee p_2) &= k \wedge p_2 \\ r \wedge (p'_1 \vee p_2) &= r \wedge p_2. \end{aligned}$$

These equations are used repeatedly in the following calculations.

If  $p_2 \wedge r = p_*$ , then by  $\text{SD}_{\wedge}$  we have  $p_* = p_1 \wedge k = p_2 \wedge r = (p_1 \vee p_2) \wedge k$ . In that case  $\mathbf{S}$  is isomorphic to  $\mathbf{G}_{20}$ .

So let us assume that  $p_2 \wedge r \not\leq p_1$ . Observe that  $p < p \vee (r \wedge p_2) \leq p_2$ . If perchance  $k \wedge (p'_1 \vee (r \wedge p_2)) \leq r$ , then  $\{p'_1, p, p_*, p'_1 \vee (r \wedge p_2), p \vee (r \wedge p_2), r \wedge p_2, 1, k, r\}$  is a sublattice of  $\mathbf{L}$  isomorphic to  $\mathbf{G}_{21}$ .

Thus we may assume that  $k \wedge (p'_1 \vee (r \wedge p_2)) \not\leq r$ , so that  $r \vee (k \wedge (p'_1 \vee (r \wedge p_2))) = k$ . If it happens that  $k \wedge (p'_1 \vee (r \wedge p_2)) \leq p \vee (r \wedge p_2)$ , then  $\{p'_1, p, p_*, p'_1 \vee (r \wedge p_2), p \vee (r \wedge p_2), k \wedge (p'_1 \vee (r \wedge p_2)), r \wedge p_2, 1, k, r\}$  is a sublattice of  $\mathbf{L}$  isomorphic to  $\mathbf{G}_{22}$ .

So let us assume that  $k \wedge (p'_1 \vee (r \wedge p_2)) \not\leq p \vee (r \wedge p_2)$ . Then check that  $\{p'_1, p, p_*, p'_1 \vee (r \wedge p_2), p \vee (r \wedge p_2), k \wedge (p'_1 \vee (r \wedge p_2)), k \wedge (p \vee (r \wedge p_2)), p \vee (k \wedge (p'_1 \vee (r \wedge p_2))), 1, k\}$  (omitting  $r$  and  $r \wedge p_2$ ) is a sublattice of  $\mathbf{L}$  isomorphic to  $\mathbf{G}_{23}$ . (Alternately, since  $\mathbf{G}_{23}$  is a splitting lattice, we can check that its splitting equation fails in  $\mathbf{L}$ .)  $\square$

**Lemma 39.** *Let  $\mathbf{L}$  be a finite, breadth 2, semidistributive lattice. Assume*

1.  $1_{\mathbf{L}} = p \vee r$  and  $r = r_1 \wedge r_2$ , both canonically,

2.  $(k \wedge l) \vee r = k$ , where  $k = \kappa(p)$  and  $l = \kappa(r)$ .

Then  $\mathbf{L}$  contains a sublattice isomorphic to one of the big lattices  $\mathbf{G}_{24}$  or  $\mathbf{G}_{25}$ , and hence  $\mathbf{L}$  is big.

*Proof.* Let  $\mathbf{S} = \text{Sg}(\{k, l, r_1, r_2\})$ . For all  $w \in S$ , either  $w \geq l$  or  $w \leq k$  exclusively. Hence in  $\mathbf{S}$  we have  $1 = l \vee r$  canonically, and  $1 \succ l$ . Since  $(k \wedge l) \vee r = k$ , we have  $k \succ k \wedge l$ . By Lemma 37, say  $r_1 \wedge l = r_*$ . It follows that  $r_1 \vee r_2 < k$ , because  $r_1 \vee r_2 = k$  would imply by  $\text{SD}_\wedge$  that

$$\begin{aligned} k &= r_1 \vee r_2 = r \wedge (k \vee l) \\ &= r \vee (r_1 \wedge l) \vee (r_2 \wedge l) \\ &= r \vee (r_2 \wedge l) \\ &\leq r_2, \end{aligned}$$

which is a contradiction since  $r_1 \leq k$ .

If also  $r_2 \wedge l = r_*$ , then by  $\text{SD}_\wedge$  we have  $(r_1 \vee r_2) \wedge l = r_*$ . In that case  $\{1, k, l, k \wedge l, r_1 \vee r_2, r_1, r_2, r, r_*\}$  is a sublattice of  $\mathbf{L}$  isomorphic to  $\mathbf{G}_{24}$ . Thus we may assume that  $r_2 \wedge l \not\leq r_1$ .

Choose  $r'_1$  such that  $r < r'_1 \leq r_1$ , and note that  $r_2 < r'_1 \vee r_2$ . Then  $l \wedge (r'_1 \vee r_2) \leq r_2$ , for otherwise  $\text{SD}_\vee$  would yield  $r'_1 \vee r_2 = [l \wedge (r'_1 \vee r_2)] \vee r_2 = (r'_1 \wedge l) \vee r_2 = r_2$ , a contradiction. Thus  $\{1, k, l, k \wedge l, r_2 \wedge l, r \vee (r_2 \wedge l), r'_1 \vee (r_2 \wedge l), r'_1, r, r_*\}$  is a sublattice of  $\mathbf{L}$  isomorphic to  $\mathbf{G}_{25}$ .  $\square$

Now we consider the first possibility in the proof of Theorem 35.

**Case 1:**  $p$  and  $r$  are both meet reducible. In this event, Lemma 38 implies that either one of  $\mathbf{G}_{20}$ ,  $\mathbf{G}_{21}$ ,  $\mathbf{G}_{22}$  or  $\mathbf{G}_{23}$  is a sublattice of  $\mathbf{L}$ , or  $p_* \vee r = k$ . In the former case  $\mathbf{L}$  is big, while in the latter Lemma 39 implies that  $\mathbf{G}_{24}$  or  $\mathbf{G}_{25}$  is a sublattice of  $\mathbf{L}$ , whence again it is big.

**Lemma 40.** *Let  $\mathbf{L}$  be a finite, breadth 2, semidistributive lattice with  $1_{\mathbf{L}} = p \vee r$  and  $r = r_1 \wedge r_2$ , both canonically. Assume that  $\mathbf{L}$  contains no sublattice isomorphic to any  $\mathbf{G}_i$  with  $20 \leq i \leq 23$ . Then for any element  $t$  with  $p < t \leq \kappa(r)$  we have  $t = p \vee (r \wedge t)$ ; in particular,  $r \wedge t \not\leq p$ .*

*Proof.* Apply Lemma 38 to  $\text{Sg}(\{r_1, r_2, p, t\})$ , with  $p$  and  $r$  interchanged, noting that in this sublattice  $\kappa(r) = t$  and  $r_* = r \wedge t$ .  $\square$

**Lemma 41.** *Let  $\mathbf{L}$  be a finite, breadth 2, semidistributive lattice. Assume*

1.  $1_{\mathbf{L}} = p \vee r$  and  $r = r_1 \wedge r_2$ , both canonically,
2.  $r_* \vee p = l$  and  $r_1 \wedge l = r_*$ , where  $l = \kappa(r)$ .
3.  $r_2 \wedge p \leq r_*$ .

*Then  $\mathbf{L}$  contains a sublattice isomorphic to one of the big lattices  $\mathbf{G}_{24}^d$  or  $\mathbf{G}_{26}^d$ . Hence  $\mathbf{L}$  is big.*

*Proof.* If it happens that  $r_2 \wedge l = r_*$ , then by  $\text{SD}_\wedge$  we have  $r_* = (r_1 \vee r_2) \wedge l$ . In that case  $\{1, l, p, p \wedge r, r_1 \vee r_2, r_1, r_2, r, r_*\}$  is a sublattice of  $\mathbf{L}$  isomorphic to the dual of  $\mathbf{G}_{24}$ . Thus we may assume that  $r_2 \wedge l \not\leq r_1$ .

Choose  $r'_1$  such that  $r \prec r'_1 \leq r_1$ , and note that  $r_2 \prec r'_1 \vee r_2$ . Then  $l \wedge (r'_1 \vee r_2) \leq r_2$ , for otherwise  $\text{SD}_\vee$  would yield  $r'_1 \vee r_2 = [l \wedge (r'_1 \vee r_2)] \vee r_2 = (r'_1 \wedge l) \vee r_2 = r_2$ , a contradiction. However,  $p \wedge r = p \wedge r'_1 = p \wedge r_2 = p \wedge (r'_1 \vee r_2)$  does hold by  $\text{SD}_\wedge$ . Thus  $\{1, l, p, r_2 \wedge l, r \vee (r_2 \wedge l), r'_1 \vee (r_2 \wedge l), r'_1, r, r_*, p \wedge r\}$  is a sublattice of  $\mathbf{L}$  isomorphic to  $\mathbf{G}_{26}^d$ .  $\square$

Since the conditions in (2) of Lemma 41 must hold if  $\mathbf{L}$  is to be small, we can now assume that (3) fails when (1) holds, i.e., that  $r_2 \wedge p \not\leq r_*$ . In particular, this means that  $p_* \not\leq r$ .

Recall that, because  $\mathbf{L}$  satisfies  $\text{SD}_\wedge$ , if  $p$  is not meet prime then there exists  $x \in L$  such that  $p \not\leq x$  and  $p \geq p^* \wedge x$ . (If  $p \geq x \wedge y$  properly, then either  $p \geq p^* \wedge x$  or  $p \geq p^* \wedge y$ , for otherwise  $p^* = p \vee (p^* \wedge x) = p \vee (p^* \wedge y) = p \vee (p^* \wedge x \wedge y) = p$ , a contradiction.)

**Lemma 42.** *Let  $\mathbf{L}$  be a finite, breadth 2, semidistributive lattice. Assume that there exist elements  $p, x, u \in L$  such that*

1.  $p$  is join prime and meet irreducible,
2.  $x \not\leq p$  and  $p^* \wedge x \leq p$ ,
3.  $p > p_* > u > p \wedge x$ ,
4.  $x \vee u \not\leq p_*$ ,
5.  $p^* \wedge (x \vee u) \not\leq p$ .

*Then  $\mathbf{L}$  contains a sublattice isomorphic to one of the big lattices  $\mathbf{G}_{27}^d$  or  $\mathbf{G}_{28}^d$ . Hence  $\mathbf{L}$  is big.*

*Proof.* These conditions ensure that  $\{p^*, p, p_*, p \wedge (x \vee u), p \wedge x, p \vee x, p_* \vee x, x \vee u, x, p^* \wedge (p_* \vee x), p^* \wedge (x \vee u), p_* \vee (p^* \wedge (x \vee u))\}$  is a sublattice of  $\mathbf{L}$ . If  $p_* \vee (p^* \wedge (x \vee u)) = p^* \wedge (p_* \vee x)$ , then it is isomorphic to  $\mathbf{G}_{27}^d$ ; if not, then to  $\mathbf{G}_{28}^d$ .  $\square$

**Lemma 43.** *Let  $\mathbf{L}$  be a finite, breadth 2, semidistributive lattice. Assume that there exist elements  $p, x, t \in L$  such that*

1.  $p$  is join prime and meet irreducible, and  $p^* \wedge \kappa(p) \not\leq p$ ,
2.  $x \not\leq p$  and  $p^* \wedge x \leq p$ ,
3.  $x < t < p_* \vee x$ ,
4.  $p^* \wedge t \leq p$ .

*Then  $\mathbf{L}$  contains a sublattice isomorphic to one of the big lattices  $\mathbf{G}_{21}^d$  or  $\mathbf{G}_{25}^d$ , and hence  $\mathbf{L}$  is big.*

*Proof.* Note that  $p^* \wedge (p_* \vee x) \not\leq p$ , or else  $p_* = p^* \wedge (p_* \vee x) = p \wedge \kappa(p)$  would imply by  $\text{SD}_\wedge$  that  $p_* = p^* \wedge \kappa(p)$ , contrary to (1). If  $p^* \wedge t \leq x$ , then  $\{p^*, p, p_*, p \vee x, p_* \vee x, p^* \wedge (p_* \vee x), t, x, p \wedge x\}$  is a sublattice of  $\mathbf{L}$  isomorphic to  $\mathbf{G}_{21}^d$ . On the other hand, if  $p^* \wedge t \not\leq x$ , then  $\{p^*, p, p_*, p \vee x, p_* \vee x, p^* \wedge (p_* \vee x), p \wedge t, x \vee (p \wedge t), x, p \wedge x\}$  is a sublattice of  $\mathbf{L}$  isomorphic to  $\mathbf{G}_{25}^d$ .  $\square$

Combining the two preceding lemmas, with the substitution  $t = x \vee u$  in the second, we can eliminate the fifth condition of Lemma 42.

**Lemma 44.** *Let  $\mathbf{L}$  be a finite, breadth 2, semidistributive lattice. Assume that there exist elements  $p, x, u \in L$  such that*

1.  $p$  is join prime and meet irreducible, and  $p^* \wedge \kappa(p) \not\leq p$ ,
2.  $x \not\leq p$  and  $p^* \wedge x \leq p$ ,
3.  $p > p_* > u > p \wedge x$ ,
4.  $x \vee u \not\leq p_*$ .

*Then  $\mathbf{L}$  is big.*

Lemma 44 will be used most often with  $u = p \wedge r$ ,  $x \leq r$  and  $p_* \not\leq r$ , which makes (4) automatic.

Now we can deal with the next case of the proof of Theorem 35.

**Case 2:**  $p$  is meet irreducible (but not meet prime) and  $r$  is meet reducible (or *vice versa*). Thus  $r = r_1 \wedge r_2$ , and there is an element  $x \in L$  such that  $p \not\leq x$  but  $p \geq p^* \wedge x$ . We may take  $x$  to be minimal with respect to  $x \not\leq p$ , so that  $x$  is join irreducible and  $x_* = p \wedge x$ . We want to prove that  $\mathbf{L}$  is big.

By Lemma 38 we may assume that  $r_* \vee p = l$ , and since  $\mathbf{L}$  has breadth 2,  $r_1 \wedge l = r_*$ . Thus by Lemma 41 we may assume that  $r_2 \wedge p \not\leq r_*$ . It follows that  $p_* \not\leq r$  and  $p \wedge r < p_*$ .

By Lemma 40 we have  $x \not\leq r$ , and hence  $x \leq l$ . If  $x \leq r$ , then we can apply Lemma 44 with  $u = p \wedge r$  to show that  $\mathbf{L}$  is big. Checking the conditions of the lemma, (3) holds because  $p \wedge r = p \wedge x = p^* \wedge x$  would imply by  $\text{SD}_\wedge$  that  $p \wedge r = p^* \wedge r$ , while by Lemma 40,  $p^* \wedge r \not\leq p$ . For (4),  $x \vee (p \wedge r) \leq r$  implies  $p_* \not\leq x \vee (p \wedge r)$ , since  $p_* \not\leq r$ .

Thus we may assume that  $x \not\leq r$ . Then  $p < p^* < p \vee x < p \vee r_* = l$  because  $p \vee x = p \vee r_*$  would imply  $p \vee x = p \vee (x \wedge r)$ , while  $x \not\leq r$  implies  $x \wedge r \leq x_* < p$ . Using Lemma 40 and the fact that  $r_1 \wedge l = r_*$ , we see that  $\{p, p^*, p \vee x, p \vee r_*, 1, p \wedge r, p^* \wedge r, (p \vee x) \wedge r, r_*, r, r_1\}$  is a sublattice of  $\mathbf{L}$  isomorphic to  $\mathbf{G}_{53}$ .

This leaves the case where both  $p$  and  $r$  are meet irreducible.

**Case 3a:**  $p$  and  $r$  are meet irreducible,  $p^* \wedge r < p$  and  $r^* \wedge p < r$ . It follows by  $\text{SD}_\wedge$  that  $p \wedge r = p^* \wedge r^*$ .

Now  $p_* \leq r^*$  would imply by  $\text{SD}_\wedge$  that  $p_* = p^* \wedge r^* = p \wedge k = p^* \wedge k$ , contrary to our assumption that  $p^* \wedge k \not\leq p$ . Thus  $p_* \not\leq r^*$ , and so  $r < r^* < p_* \vee r$ . By Lemma 43 this implies that  $\mathbf{L}$  is big.

**Case 3b:**  $p$  and  $r$  are meet irreducible,  $p^* \wedge r < p$ ,  $r^* \wedge p \not\leq r$ , and there exists  $y \in L$  with  $r^* \wedge y < r$  properly (or *vice versa* with  $p$  and  $r$  interchanged). As usual, we may choose  $y$  minimally, so that  $y$  is join irreducible and  $y_* < r$ .

First suppose that  $p_* \not\leq r^*$ . Then we can apply Lemma 44 with  $x = r$  and  $u = p \wedge r^*$  to show that  $\mathbf{L}$  is big. Checking the conditions of the lemma requires the observation that  $r \vee (p \wedge r^*) = r^* < p_* \vee r$ .

Thus we may assume that  $p_* \leq r^*$ . This in turn implies  $y \not\leq p$ , and so  $p \wedge y \leq y_* < r$ . Hence  $p \wedge y \leq r \wedge y$ . Equality cannot hold by  $\text{SD}_\wedge$ , so  $p \wedge y < r \wedge y = y_*$ . Thus  $y_* \not\leq p$ .

Consider  $p^* \wedge r^* \wedge y$ , which is below  $p \wedge r$ . Now  $p^* \wedge r^* \not\leq r$  and  $r^* \wedge y = y_* \not\leq p$ . As  $\text{br}(\mathbf{L}) = 2$ , we must have  $p^* \wedge y = p^* \wedge r^* \wedge y < r$ .

Also note that  $p \wedge r \not\leq y$ . For otherwise  $\text{SD}_\wedge$  would yield  $p^* \wedge y = p^* \wedge r = p^* \wedge (r \vee y) \geq p^* \wedge r^*$ , whereas  $p^* \wedge y < r$  and  $p^* \wedge r^* \not\leq r$ .

These preliminaries provide the setup for us to apply Lemma 44 with  $x = y_*$  and  $u = p \wedge r$ . Checking the conditions of the lemma uses  $y_* \vee (p \wedge r) \leq r$ , and  $p_* \not\leq r$  because  $p \wedge r^* \not\leq r$ .

**Case 3c:**  $p$  and  $r$  are meet irreducible,  $p^* \wedge r \not\leq p$ ,  $r^* \wedge p \not\leq r$ , and there exist  $x, y \in L$  such that  $p^* \wedge x < p$  and  $r^* \wedge y < r$  properly. Again we may take  $x$  and  $y$  to be join irreducible, with  $x_* < p$  and  $y_* < r$ .

First note that  $p_* \not\leq r$ , for otherwise  $r^* \wedge p \leq p^* \leq r$ , contrary to assumption. Likewise  $r_* \not\leq p$ .

If perchance  $x \leq r$ , then we can apply Lemma 44 with  $x$  as itself and  $u = p \wedge r$ . For condition (3) we have  $p \wedge r > p \wedge x$  because  $p \wedge r = p^* \wedge x$  would imply by  $\text{SD}_\wedge$  that  $p \wedge r = p^* \wedge (r \vee x) \geq p^* \wedge r^* \geq p \wedge r$ , a contradiction. Again we use  $x \vee (p \wedge r) \leq r$ .

Thus we may assume that  $x \not\leq r$ , and likewise  $y \not\leq p$ . In this case we can apply Lemma 44 with  $x = y_*$  and  $u = p \wedge r$ . We need to observe that  $p \wedge y \leq y_* \leq r$ . Thus  $p \wedge r \not\leq y_*$ , as  $p \wedge r = p \wedge y$  would imply  $p \wedge r = p \wedge (r \vee y) \geq p \wedge r^* \geq p \wedge r$ , a contradiction.

This completes the proof of Theorem 35.

**Corollary 45.** *Let  $\mathbf{L}$  be a finite, linearly indecomposable, breadth 2, semidistributive lattice with  $1_{\mathbf{L}} = p \vee r$  canonically, and let  $E(p)$  and  $E(r)$  denote their respective join prime units. If neither  $E(p)$  nor  $E(r)$  is doubly prime, then  $\mathbf{L}$  contains a sublattice isomorphic to an  $\mathbf{G}_i$  with  $20 \leq i \leq 28$ ,  $\mathbf{G}_{24}^d$ ,  $\mathbf{G}_{25}^d$  or  $\mathbf{G}_{53}$ .*

## 10. SEMIDISTRIBUTIVE LATTICES WITH A DOUBLY PRIME UNIT

It remains to decide which breadth 2, semidistributive lattices with a doubly prime unit are big.

**Theorem 46.** *Let  $\mathbf{L}$  be a finite, linearly indecomposable, breadth 2, semidistributive lattice containing a doubly prime unit  $E = \{e_0, \dots, e_n\}$ . Then  $\mathbf{L}$  is small if and only if the following conditions hold.*

1.  $\mathbf{L} - E$  is small.
2. For each  $b < e_0$ , the finitely presented lattice  $\mathbf{FQ}(e_0, \lambda(b))$  is finite, where  $\lambda(b) = \bigvee \{x \in L : e_0 \wedge x = b\}$ .
3. For each  $a > e_n$ , the finitely presented lattice  $\mathbf{FQ}(\mu(a), e_n)$  is finite, where  $\mu(a) = \bigwedge \{x \in L : e_n \vee x = a\}$ .

Note that these conditions are clearly necessary for  $\mathbf{L}$  to be small. So assume that  $\mathbf{L}$  satisfies (1)–(3) and that  $\mathbf{L} \prec \mathbf{K}$ . We want to show that  $\mathbf{K}$  is finite.

Let  $k = \kappa(e_0)$ ,  $l = \kappa'(e_n)$ ,  $u = e_n^*$ ,  $v = e_{0*}$ ,  $u_+ = u \wedge k$  and  $v^+ = v \vee l$ . Note that  $u \succ u_+$  and  $v \prec v^+$ . The situation is diagrammed in Figure 26.

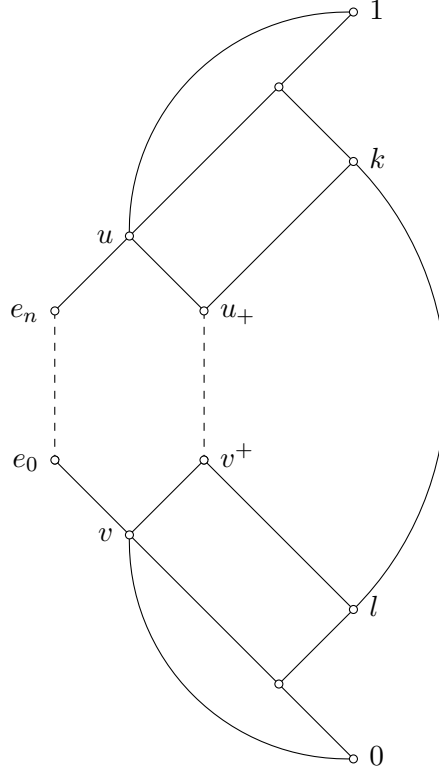

FIGURE 26.

**Claim 1:** If there exists  $p \in K - L$  with  $e_0 < p < e_n$ , then  $\mathbf{K}$  is finite. For it is easy to see that in this case  $L \cup \{p\}$  is a sublattice of  $\mathbf{K}$ , and hence equal to  $\mathbf{K}$ .

Thus we may assume that  $e_0 \leq p \leq e_n$  implies  $p \in L$ .

**Claim 2:** If there exists  $p \in K - L$  with  $p \in 1/u \cup k/l \cup v/0$ , then  $\mathbf{K}$  is finite. For in this case we can prove the following, using  $\mathbf{K} = \text{Sg}(L \cup \{p\})$  and the closure of these properties under join and meet.

1. For all  $w \in K$ , either  $w \geq e_0$  or  $w \leq k$ .
2. For all  $w \in K$ , either  $w \geq l$  or  $w \leq e_n$ .
3. For all  $w \in K$ ,  $w \in E \cup 1/u \cup k/l \cup v/0$ .

Now apply Lemma 32 with

$$\begin{aligned} \mathbf{S} &= \mathbf{L} - E \\ \mathbf{T} &= \text{Sg}(\{p\} \cup S) \\ F &= E. \end{aligned}$$

The properties above are used to verify the conditions of the lemma. We conclude that  $\mathbf{S} \prec \mathbf{T}$  and  $T \cup E = K$ . Since  $\mathbf{S}$  is small by condition (1) of the theorem, and  $E$  is finite, it follows that  $\mathbf{K}$  is finite.

Thus we may assume that in  $\mathbf{K}$ ,  $1/u \cup k/l \cup v/0 \subseteq L$ .



**Claim 3:** If for all  $p \in K - L$ ,  $p^{[\mathbf{L}]} \notin E$  and  $p_{[\mathbf{L}]} \notin E$ , then  $\mathbf{K}$  is finite. In this case we again apply Lemma 32 with

$$\begin{aligned}\mathbf{S} &= \mathbf{L} - E \\ \mathbf{T} &= \text{Sg}(\{p\} \cup S) \\ F &= E.\end{aligned}$$

To verify that  $T \cap E = \emptyset$ , we show that each  $e_i$  is doubly irreducible in  $\mathbf{K}$ . Suppose  $e_i = w_1 \wedge w_2$  in  $\mathbf{K}$ . Then  $e_i = (e_i)_{[\mathbf{L}]} = (w_1)_{[\mathbf{L}]} \wedge (w_2)_{[\mathbf{L}]}$ , whence  $e_i = (w_1)_{[\mathbf{L}]}$  say. By our hypothesis, this implies that  $w_1 = e_i$ . Thus each  $e_i$  is meet irreducible, and dually they are join irreducible.

To verify condition 3 of the lemma, let  $q \in T - S$  and let  $w \in \text{Sg}(\{q\} \cup S)$ . Then for any  $i$  we have  $e_i \vee w = (e_i \vee w)_{[\mathbf{L}]} \vee w$ . If  $e_i \vee w \notin L$ , then  $(e_i \vee w)_{[\mathbf{L}]} \geq e_i$  implies  $(e_i \vee w)_{[\mathbf{L}]} \geq u$ , whence  $e_i \vee w \in L$  by Claim 2, a contradiction. Hence  $e_i \vee w \in L \subseteq E \cup \text{Sg}(\{q\} \cup S)$ . Dually,  $e_i \wedge w \in E \cup \text{Sg}(\{q\} \cup S)$ .

Thus we may assume that, say, there exists  $p \in K - L$  with  $p^{[\mathbf{L}]} \in E$ .

**Claim 4:** If there exists  $p \in K - L$  with  $p^{[\mathbf{L}]} \in E$ , then  $\mathbf{K}$  is finite. Let  $p^{[\mathbf{L}]} = e_s$  with  $s$  minimal, and let  $p_{[\mathbf{L}]} = b$ . By Claim 1,  $b \notin E$  so  $b \leq v$ . Let  $m = \lambda(b)$ , so that for  $x \in L$  and  $e_i \in E$ , we have  $e_i \wedge (b \vee x) = b$  if and only if  $b \leq m$ .

Now by Lemma 33 the sublattice

$$\mathbf{M} = \text{Sg}_{\mathbf{K}}(\{p \vee x : x \in L \cap m/b\} \cup \{(p \vee m) \wedge y : y \in L \cap (e_s \vee m)/e_s - \{e_s\}\})$$

is finite, since  $\mathbf{M}$  is a homomorphic image of  $\mathbf{FQ}(e_s, \lambda(b))$ , which in turn is a homomorphic image of  $\mathbf{FQ}(e_0, \lambda(b))$ , which is finite. It remains to show that  $L \cup M$  is a sublattice of  $\mathbf{K}$ , and hence equal to  $\mathbf{K}$ .

Note that since  $\mathbf{K}$  is generated by  $L \cup \{p\}$ , the following hold.

1. For all  $w \in K$ , either  $w \geq l$  or  $w \leq e_n$ .
2. For all  $w \in K$ , either  $w \geq p$  or  $w \leq k$  or  $w = e_i$  with  $i \in \{0, \dots, s-1\}$ .

Showing that the second condition is closed under meets and joins requires a little care. Consider  $e_i \vee w$  with  $i < s$  and  $w \in K$ . If  $w \geq l$  then  $e_i \vee w \geq u \geq e_s \geq p$ , while if  $w \leq e_n$  then  $e_i \leq e_i \vee w \leq e_n$ , whence  $e_i \vee w \in E$  by Claim 1. In either event the condition follows. On the other hand,  $e_i \geq e_i \wedge w$  implies  $e_i \wedge w \in L$ , whence  $e_i \wedge w \in E$  or  $e_i \wedge w \leq u \leq k$ .

It follows from (2) and  $v/0 \subseteq L$  (Claim 2) that  $p$  is the only element of  $K - L$  in  $e_s/0$ .

Now let  $x \in L$  and  $w \in M$ . Note that  $p \leq w \leq p \vee m$ . First we consider  $x \vee w$ .

1. If  $x \in E$  and  $w \leq e_n$ , then  $x \vee w \in e_n/e_0$ , and hence  $x \vee w \in E$  by Claim 1.
2. If  $x \in E$  and  $w \geq l$ , then  $x \vee w \geq u$ , and hence  $x \vee w \in L$  by Claim 2.
3. If  $x \geq u$ , then  $x \vee w \in 1/u \subseteq L$ .
4. If  $x \leq m$ , then  $x \vee w = ((x \vee b) \vee p) \vee w \in M$  because  $(x \vee b) \vee p \in M$ .

5. If  $x \leq k$  but  $x \not\leq m$ , then

$$\begin{aligned} x \vee w &= x \vee w \vee [e_s \wedge (b \vee x)] \vee p \\ &= x \vee w \vee e_s \end{aligned}$$

because  $b < e_s \wedge (b \vee x) \leq v$ . (This case does not arise when  $b = v$  because  $m = k$ .) Thus if  $x$  or  $w \geq l$  then  $x \vee w \geq u$ , while if  $x$  and  $w \leq e_n$  then  $e_s \leq x \vee w \leq e_n$ . Either way,  $x \vee w \in L$ .

Now consider  $x \wedge w$ .

1. If  $x \leq k$  and  $x \wedge w \geq l$ , then  $x \wedge w \in k/l \subseteq L$ .
2. If  $x \leq k$  and  $x \wedge w \leq e_n$ , then  $x \wedge w \leq k \wedge e_n = v$ , so again  $x \wedge w \in L$ .
3. If  $x \geq e_s$ , then

$$x \wedge w = [x \wedge (e_s \vee m)] \wedge (p \vee m) \wedge w$$

which is in  $M$  because  $[x \wedge (e_s \vee m)] \wedge (p \vee m) \in M$ .

4. If  $x = e_i$  with  $0 \leq i < s$ , then  $x \wedge w \in L$  since  $p$  is the only element of  $K - L$  in  $e_s/0$ .

Thus  $LUM$  is a sublattice of  $\mathbf{K}$ . So  $LUM = K$  and  $\mathbf{K}$  is finite, completing the proof of Theorem 46.

**Corollary 47.** *If  $\mathbf{L}$  is a finite, breadth 2, semidistributive, minimal big lattice containing a doubly prime unit, then there exist  $x, y \in L$  such that  $L$  is the disjoint union of  $1/x$  and  $y/0$ , and  $\mathbf{FQ}(x, y)$  is infinite.*

## 11. AN ALGORITHM FOR DETERMINING SMALLNESS

Combining all the previous results yields an algorithm for determining whether a finite lattice is big or small.

**Theorem 48.** *Let  $\mathbf{L}$  be a finite lattice.*

1. *If  $\mathbf{L}$  is linearly decomposable, say  $\mathbf{L} \cong \mathbf{L}_0 + \mathbf{L}_1$ , then  $\mathbf{L}$  is small if and only if both  $\mathbf{L}_0$  and  $\mathbf{L}_1$  are small.*
2. *If  $\mathbf{L}$  is linearly indecomposable and  $\text{br}(\mathbf{L}) > 2$ , then  $\mathbf{L}$  is big unless  $\mathbf{L} \cong \mathbf{B}_3$ , and  $\mathbf{B}_3$  is small.*
3. *If  $\mathbf{L}$  is linearly indecomposable,  $\text{br}(\mathbf{L}) = 2$ , and  $\mathbf{L}$  does not satisfy  $\text{SD}_\wedge$ , then  $\mathbf{L}$  is big unless  $\mathbf{L}$  contains a sublattice  $\{a, b, c, d, f, u, z\}$  isomorphic to  $\mathbf{D}_1$  (as labelled in Figure 23) such that*
  - i.  $L = D_1 \cup 1/d \cup 1/f$  (so  $z = 0$ ),
  - ii.  $\mathbf{L} - \{a\}$  and  $\mathbf{L} - \{c\}$  are small lattices satisfying  $\text{SD}_\wedge$ ,
  - iii.  $a$  and  $c$  are join prime,
  - iv.  $\mathbf{FQ}(a, \kappa(a))$  and  $\mathbf{FQ}(c, \kappa(c))$  are finite.*If  $\mathbf{L}$  satisfies i–iv, then it is small.*
4. *The dual criterion applies if  $\mathbf{L}$  is linearly indecomposable,  $\text{br}(\mathbf{L}) = 2$ , and  $\mathbf{L}$  fails  $\text{SD}_\vee$ .*
5. *If  $\mathbf{L}$  is linearly indecomposable, semidistributive,  $\text{br}(\mathbf{L}) = 2$ , and  $1_{\mathbf{L}} = p \vee r$  canonically, and the join prime units  $E(p)$  and  $E(r)$  are neither one doubly prime, then  $\mathbf{L}$  is big.*

6. If  $\mathbf{L}$  is linearly indecomposable, semidistributive,  $\text{br}(\mathbf{L}) = 2$ , and  $\mathbf{L}$  contains a doubly prime unit  $E = \{e_0, \dots, e_n\}$ , then  $\mathbf{L}$  is small if and only if the following conditions hold.
- i.  $\mathbf{L} - E$  is small.
  - ii. For each  $b < e_0$ , the finitely presented lattice  $\mathbf{FQ}(e_0, \lambda(b))$  is finite, where  $\lambda(b) = \bigvee\{x \in L : e_0 \wedge x = b\}$ .
  - iii. For each  $a > e_n$ , the finitely presented lattice  $\mathbf{FQ}(\mu(a), e_n)$  is finite, where  $\mu(a) = \bigwedge\{x \in L : e_n \vee x = a\}$ .

## 12. THE LARGEST MINIMAL EXTENSION OF A SMALL LATTICE

Let us note one more interesting consequence of the arguments given so far. As we have seen, there are other types of minimal extensions besides those given by the construction of Theorem 26. However, in this section we will prove that, for small lattices, the construction always gives the largest minimal extension.

**Theorem 49.** *If  $\mathbf{L}$  is a small lattice with  $|L| > 1$  and  $\mathbf{L} \prec \mathbf{K}$ , then  $|K| \leq |L| + q$  where  $q = \max(|\mathbf{FQ}(x, y)| : x, y \in L \text{ and } x \parallel y)$ .*

This justifies the bounds given for minimal extensions of small lattices in Section 5. We should note that it is not obvious that a small lattice has a largest minimal extension. For example, the one element group is small as a group, but  $\{0\} \prec \mathbf{Z}_p$  for all primes  $p$ . See Section 20 for a discussion of these properties in other varieties.

For a finite lattice  $\mathbf{L}$  with  $|L| > 1$ , let

$$\mu(\mathbf{L}) = \max(|K| : \mathbf{L} \prec \mathbf{K})$$

and let  $\delta(\mathbf{L}) = \mu(\mathbf{L}) - |L|$ . Moreover, define

$$q(\mathbf{L}) = \max(|\mathbf{FQ}(p, k)| : p, k \in L \text{ and } p \parallel k).$$

Our goal is to prove that  $\delta(\mathbf{L}) = q(\mathbf{L})$ , and thus  $\mu(\mathbf{L}) = |L| + q(\mathbf{L})$ .

Of course, by the construction of Theorem 26 we have  $\delta(\mathbf{L}) \geq q(\mathbf{L})$ . The proof of the reverse inequality is by induction on  $|L|$ . The following facts are relevant.

**Fact 1.** If  $\mathbf{S} \leq \mathbf{L}$ , then  $\delta(\mathbf{S}) \leq \delta(\mathbf{L})$ .

**Fact 2.** If  $\mathbf{S} \leq \mathbf{L}$ , then  $q(\mathbf{S}) \leq q(\mathbf{L})$ .

These are consequences of the proofs of Theorems 7 and 53, respectively. (Theorem 53 will be proved later in this section.)

The only small lattice of breadth 3 or more is  $\mathbf{B}_3$ , for which  $\delta(\mathbf{B}_3) = q(\mathbf{B}_3) = 6$ . See Figure 10.

For non-semidistributive lattices, we refine Theorem 31 as follows.

**Theorem 50.** *Let  $\mathbf{L}$  be a finite, linearly indecomposable, breadth 2 lattice which does not satisfy  $\text{SD}_\wedge$ . Then either  $\mathbf{L}$  is big or  $\mathbf{L}$  contains a sublattice  $\{a, b, c, d, f, u, z\}$  isomorphic to  $\mathbf{D}_1$  such that*

1.  $L = D_1 \cup 1/d \cup 1/f$  (so  $z = 0$ ),
2.  $\mathbf{L} - \{a\}$  and  $\mathbf{L} - \{c\}$  satisfy  $\text{SD}_\wedge$ ,

3.  $a$  and  $c$  are join prime,
4.  $\delta(\mathbf{L}) \leq \max(\delta(\mathbf{L} - \{a\}), \delta(\mathbf{L} - \{c\}), |\mathbf{FQ}(a, \kappa(a))|, |\mathbf{FQ}(c, \kappa(c))|)$ .

The details are provided by applications of Lemmas 32 and 33. Whenever Lemma 32 is applied, we are in a situation with  $\mathbf{S} < \mathbf{L} \prec \mathbf{K}$  and  $\mathbf{S} < \mathbf{T}$ ; the conclusion is that  $\mathbf{S} \prec \mathbf{T}$  and  $|K - L| = |T - S|$ . Whenever Lemma 33 is applied, we are in a situation with  $\mathbf{L} \prec \mathbf{K}$  and  $K = L \cup M$ ; the conclusion is that  $|M| \leq |\mathbf{FQ}(a, m)|$  for some  $a, m$ .

For semidistributive lattices, first recall that by Theorem 35 a finite, linearly indecomposable, breadth 2, semidistributive lattice which is small must contain a doubly prime unit.

Finally, we refine Theorem 46 as follows.

**Theorem 51.** *Let  $\mathbf{L}$  be a finite, linearly indecomposable, breadth 2, semidistributive lattice containing a doubly prime unit  $E = \{e_0, \dots, e_n\}$ . Then either  $\mathbf{L}$  is big or*

$$\delta(\mathbf{L}) \leq \max(\delta(\mathbf{L} - E), |\mathbf{FQ}(e_0, \lambda(b))| \text{ for all } b < e_0, \\ |\mathbf{FQ}(\nu(a), e_n)| \text{ for all } a > e_n)$$

where  $\lambda(b) = \bigvee\{x \in L : e_0 \wedge x = b\}$  and  $\nu(a) = \bigwedge\{x \in L : e_n \vee x = a\}$ .

So we conclude by induction that every small lattice has a largest minimal extension, given by the construction of Theorem 26.

This is an appropriate place to discuss the structure of small lattices, even though we must use some results from later on. For non-semidistributive small lattices, we have the structural Theorem 31 and its dual. As an additional comment, let us show that a small semidistributive lattice is bounded (in the sense of McKenzie).

We need to recall the relations  $A$ ,  $B$ , and  $C = A \cup B$  on the join irreducible elements of a finite semidistributive lattice, and also to recall that a finite, nonbounded, semidistributive lattice contains a minimal  $C$ -cycle which contains both  $A$ 's and  $B$ 's. (See e.g. [5], Chapter II, Section 5.) These relations are defined by

$$\begin{aligned} p A q & \text{ if } q < p < q \vee \kappa(q), \\ p B q & \text{ if } p \neq q, p \leq p_* \vee q \text{ and } p \not\leq p_* \vee q_*, \\ p C q & \text{ if either } p A q \text{ or } p B q, \end{aligned}$$

where  $\kappa(q)$  denotes the largest element  $x$  such that  $q \wedge x = q_*$ .

**Theorem 52.** *Let  $\mathbf{L}$  be a finite, breadth 2, semidistributive lattice. If  $\mathbf{L}$  contains join irreducible elements  $p, q$  such that  $p A q B r$  and not  $p B r$ , then  $\mathbf{L}$  is big.*

*Proof.* Let  $l = \kappa(q)$ , and note that  $r_* \leq l < l^* = q \vee l$  but  $r \not\leq l^*$  else  $l^* = r \vee l = q \vee l = (q \wedge r) \vee l = l$ , a contradiction.

If  $p \not\leq q \vee r$ , then  $l, p \vee r_*, q \vee r$  is a 3 element antichain in  $\mathbf{Q}(r, l^*)$ , and  $\mathbf{L}$  is big by Theorem 62. (If  $l \leq p \vee r_*$ , then  $l^* = q \vee l = p \vee r_* = q \vee (l \wedge p) \vee r_*$ , while no two of these terms join above  $p$ .)

So we may assume that  $p \leq q \vee r \leq p_* \vee r$ . Since not  $p B r$ , this implies  $p \leq p_* \vee r_*$ . But then, in  $\mathbf{Q}(q_*, r)$ , the elements  $p_*, p, q_* \vee r_*$  satisfy the conditions of Lemma 66, making  $\mathbf{L}$  big.  $\square$

**$\mathbf{FQ}(p, k)$  and Sublattices.** The finitely presented lattice  $\mathbf{FQ}_{\mathbf{L}}(p, k)$  is determined by the sublattice  $(p \vee k)/p \cup k/(p \wedge k)$  of  $\mathbf{L}$ . The following result summarizes how the cardinality of  $\mathbf{FQ}_{\mathbf{L}}(p, k)$  depends on the parameters  $\mathbf{L}$ ,  $p$  and  $k$ .

**Theorem 53.** *Let  $\mathbf{L}$  be a finite lattice with  $L = (p \vee k)/p \cup k/(p \wedge k)$ . Suppose there is a sublattice  $\mathbf{S}$  of  $\mathbf{L}$  containing elements  $p' \geq p$  and  $k' \leq k$ . Then  $|\mathbf{FQ}_{\mathbf{S}}(p', k')| \leq |\mathbf{FQ}_{\mathbf{L}}(p, k)|$ . In particular, if  $\mathbf{FQ}_{\mathbf{S}}(p', k')$  is infinite, then  $\mathbf{FQ}_{\mathbf{L}}(p, k)$  is infinite.*

Let us begin with the case when  $p' = p$  and  $k' = k$ . Note that this case suffices to prove Fact 2 above: *If  $\mathbf{S} \leq \mathbf{L}$ , then  $q(\mathbf{S}) \leq q(\mathbf{L})$ .*

**Lemma 54.** *The conclusion of Theorem 53 is true if  $p' = p$  and  $k' = k$ .*

In fact, the argument for this lemma works if  $p' = p \vee (p' \wedge k')$  and  $k' = k \wedge (p' \vee k')$ , but not in general.

*Proof.* Let  $\mathbf{Q}_{\mathbf{L}}(p, k) = \{q_t : t \in L\}$  with  $q_k = q_{p \vee k}$  and  $q_p = q_{p \wedge k}$ , and  $\mathbf{Q}_{\mathbf{S}}(p, k) = \{r_s : s \in S\}$  with  $r_k = r_{p \vee k}$  and  $r_p = r_{p \wedge k}$ . We prove that  $\mathbf{FQ}_{\mathbf{S}}(p, k)$  is a homomorphic image of  $\text{Sg}(\{q_s : s \in S\})$  in  $\mathbf{FQ}_{\mathbf{L}}(p, k)$ . Let  $X = \{x_s : s \in S\}$ , and let  $f : \mathbf{FL}(X) \rightarrow \mathbf{FQ}_{\mathbf{L}}(p, k)$  and  $g : \mathbf{FL}(X) \rightarrow \mathbf{FQ}_{\mathbf{S}}(p, k)$  be the natural maps with  $f(x_s) = q_s$  and  $g(x_s) = r_s$ . We want to show that  $\ker f \leq \ker g$ , i.e., that  $f(u) \leq f(v)$  implies  $g(u) \leq g(v)$ . The proof is by induction on the complexities of  $u$  and  $v$ .

First we need another lemma.

**Lemma 55.** *Let  $\mathbf{L}, p, k, \mathbf{S}$  be as above. If  $w \geq q_t$  with  $w \in \text{Sg}(\{q_s : s \in S\})$  and  $t \in L \cap k/0$ , then there exists  $t' \in S \cap k/0$  such that  $w \geq q_{t'} \geq q_t$ .*

*Proof.* Again we use induction on the complexity of  $w$ . If  $w = q_s$  with  $s \in S$ , take  $t' = s \wedge k$ .

Suppose  $\bigvee w_i \geq q_t$ . Then there exists  $U \subseteq L$  such that  $\{q_u : u \in U\} \ll \{w_1, \dots, w_k\}$  and  $q_t \leq \bigvee q_u$ . Without loss of generality  $U \subseteq k/0$ , as every proper join in  $\mathbf{Q}_{\mathbf{L}}$  refines to one of this type. For each  $u \in U$  there exists  $w_i$  such that  $q_u \leq w_i$ , and by induction there exists  $u' \in S \cap k/0$  with  $q_u \leq q_{u'} \leq w_i$ . Let  $U'$  denote the set of all such  $u'$  for  $u \in U$ . Then  $q_t \leq \bigvee q_u \leq \bigvee q_{u'} = q_{\bigvee U'} \leq \bigvee w_i$ , so we can take  $t' = \bigvee U'$ .

Suppose  $\bigwedge w_i \geq q_t$ . By induction, for each  $i$  there exists  $t'_i \in S \cap k/0$  such that  $w_i \geq q_{t'_i} \geq q_t$ . Since  $t'_i \geq t$  for each  $i$ , we have  $\bigwedge t'_i \geq t$  and  $\bigwedge q_{t'_i} \in S \cap k/0$ . Moreover,  $\bigwedge w_i \geq \bigwedge q_{t'_i} \geq q_{\bigwedge t'_i} \geq q_t$ , as desired.  $\square$

Now we proceed with the proof. First suppose  $u$  and  $v$  are generators, say  $u = x_{s_1}$  and  $v = x_{s_2}$  with  $s_1, s_2 \in S$ . Then  $f(x_{s_1}) \leq f(x_{s_2})$ , i.e.,  $q_{s_1} \leq q_{s_2}$  holds if and only if  $s_1 \leq s_2$  or  $s_1 = p$  or  $s_2 = k$ . Hence  $q_{s_1} \leq q_{s_2}$  implies  $r_{s_1} \leq r_{s_2}$ , i.e.,  $g(x_{s_1}) \leq g(x_{s_2})$ .

The cases where  $u$  is a join or  $v$  is a meet are easy.

Suppose  $u$  is a generator and  $v$  is a join, say  $u = x_s$  and  $v = \bigvee v_i$ . Then  $f(u) \leq f(v)$  means  $q_s \leq \bigvee f(v_i)$  in  $\mathbf{FQ}_L(p, k)$ . This refines to a join cover  $q_s \leq \bigvee \{q_t : t \in T\}$  with  $T \subseteq L \cap k/0$ , and either  $s \leq \bigvee T$  or  $\bigvee T = k$ . For each  $t \in T$  there exists  $i$  such that  $q_t \leq f(v_i)$ . By the lemma above, there exists  $t' \in S \cap k/0$  such that  $q_t \leq q_{t'} \leq f(v_i)$ . Let  $T'$  denote the set of all such  $t'$  for  $t \in T$ . By induction, we have  $g(x_{t'}) \leq g(v_i)$  for all  $t' \in T'$ . If  $s \leq \bigvee T$ , then  $g(x_s) = r_s \leq r_{\bigvee T'} = g(\bigvee_{t' \in T'} x_{t'}) \leq g(\bigvee v_i) = g(v)$ . But if  $\bigvee T = k$ , then  $k = \bigvee T' \in S$  implies  $r_k \leq \bigvee g(v_i)$  as before, whence  $g(x_s) = r_s \leq r_{p \vee k} = r_k \leq g(\bigvee v_i)$ .

Dually, the claim holds when  $u$  is a meet and  $v$  is a generator. The final case, when  $u$  is a meet and  $v$  is a join, follows from the fact that  $\mathbf{FQ}_L(p, k)$  satisfies (W).  $\square$

**Lemma 56.** *The conclusion of Theorem 53 is true if  $p' = p$  and  $p \wedge k < k' \leq k$  and  $\mathbf{S} = p \vee k'/p \cup k'/p \wedge k$ .*

Applying Lemma 54, then Lemma 56, and then the dual of Lemma 56 yields the proof of Theorem 53.

*Proof.* Let  $\mathbf{R} = \mathbf{Q}_S(p, k') = \{r_s : s \in S\}$  with  $r_{k'} = r_{p \vee k'}$  and  $r_p = r_{p \wedge k}$ , and let  $\mathbf{FR} = \mathbf{FQ}_S(p, k')$ .

**Step 1.** Using the construction of Theorem 26, glue  $\mathbf{FR}$  into  $\mathbf{L}$  to form the lattice  $\mathbf{C} = \mathbf{L} \cup \mathbf{FR}$ . We take  $A = (p \vee k')/p$  and  $B = k'/(p \wedge k)$ , and use the homomorphisms  $\alpha, \beta$  extending

$$\begin{aligned} \alpha_0(r_a) &= a & \text{for } a \in A, \\ \alpha_0(r_b) &= p \vee b & \text{for } b \in B, \\ \beta_0(r_a) &= k' \wedge a & \text{for } a \in A, \\ \beta_0(r_b) &= b & \text{for } b \in B. \end{aligned}$$

**Step 2.** The element  $p$  is completely join irreducible in  $\mathbf{C}$ , with lower cover  $p_* = r_p = r_{p \wedge k}$ . Hence  $\mathbf{C}' = \mathbf{C} - \{p\}$  with the inherited order is also a lattice. The join operation in  $\mathbf{C}'$  agrees with that in  $\mathbf{C}$ , while the meet operation differs only in that  $x \wedge y = r_p$  in  $\mathbf{C}'$  whenever  $x \wedge y = p$  in  $\mathbf{C}$ .

**Step 3.** Let  $L' = L - \{p\}$ , and let

$$\mathbf{M} = \text{Sg}_{\mathbf{C}'}(\{r_p \vee s : s \in L \cap k'/p \wedge k\} \cup \{(r_p \vee k) \wedge t : t \in L' \cap (p \vee k)/p\}).$$

Note that

$$r_p \vee k = \begin{cases} r_{p \vee k'} & \text{if } k' = k, \\ p \vee k & \text{otherwise.} \end{cases}$$

So  $M \subseteq 1/r_p$ , but usually  $M \not\subseteq \text{FR}$ . However,  $M \supseteq R$ , since  $r_b = r_p \vee b$  if  $b \in B$ , including  $r_{k'} = r_{p \vee k'}$ , and  $r_a = ((r_p \vee k) \wedge a) \wedge r_{p \vee k'}$  if  $a \in A - \{p\}$ . Hence  $\mathbf{M} \geq \mathbf{FR}$ , as the latter is a sublattice of  $\mathbf{C}'$ , and  $C' = L' \cup M$ .

**Step 4.** Now let  $h : \mathbf{Q}_{\mathbf{L}}(p, k) \rightarrow M$  be defined by

$$h(q_s) = \begin{cases} r_p \vee s & \text{if } s \in k/p \wedge k, \\ (r_p \vee k) \wedge s & \text{if } t \in L' \cap (p \vee k)/p, \\ r_p & \text{if } s = p \end{cases}$$

As in the proof of Lemma 33, check that  $h$  respects the defining relations of  $\mathbf{Q}_{\mathbf{L}}(p, k)$ . (The modification required is that if  $a \wedge a' = p$  properly in  $\mathbf{L}$ , then  $h(q_a) \wedge h(q_{a'}) = (r_p \vee k) \wedge a \wedge a' = r_p$  in  $\mathbf{C}'$ .) Hence  $h$  extends to a homomorphism  $h : \mathbf{FQ}_{\mathbf{L}}(p, k) \rightarrow \mathbf{M}$ , which is surjective because the generators of  $\mathbf{M}$  are in its range. Since  $\mathbf{M}$  is infinite, so is  $\mathbf{FQ}_{\mathbf{L}}(p, k)$ .  $\square$

### 13. CHARACTERIZING SMALLNESS BY EXCLUDED SUBLATTICES

The algorithm of the preceding section can be refined to a characterization of small lattices in terms of excluded sublattices, to wit:

**Theorem 57.** *A finite lattice is small if and only if it contains none of the 145 minimal big lattices  $\mathbf{G}_i$  or  $\mathbf{G}_i^d$  with  $1 \leq i \leq 81$  as a sublattice.*

The 145 minimal big lattices come in 81 different types up to dual isomorphism, 17 of which are self-dual and 64 of which are not.

We can summarize the reduction to the semidistributive, breadth 2 case as follows.

**Theorem 58.** *If  $\mathbf{L}$  is a finite lattice which is big and not both semidistributive and breadth 2, then  $\mathbf{L}$  contains a sublattice isomorphic to one of the big lattices  $\mathbf{G}_1, \mathbf{G}_1^d, \mathbf{G}_2, \mathbf{G}_3, \mathbf{G}_3^d, \mathbf{G}_4, \mathbf{G}_5, \mathbf{G}_6, \mathbf{G}_6^d, \mathbf{G}_7, \mathbf{G}_8, \mathbf{G}_8^d, \mathbf{G}_9, \mathbf{G}_9^d, \mathbf{G}_{10}, \mathbf{G}_{10}^d, \mathbf{G}_{11}, \mathbf{G}_{11}^d, \mathbf{G}_{12}, \mathbf{G}_{12}^d, \mathbf{G}_{13}, \mathbf{G}_{13}^d, \mathbf{G}_{14}, \mathbf{G}_{14}^d, \mathbf{G}_{15}, \mathbf{G}_{15}^d, \mathbf{G}_{16}, \mathbf{G}_{16}^d, \mathbf{G}_{17}, \mathbf{G}_{17}^d, \mathbf{G}_{18}, \mathbf{G}_{18}^d, \mathbf{G}_{19}, \mathbf{G}_{19}^d$ , or a sublattice which is big, semidistributive and breadth 2.*

**Theorem 59.** *If  $\mathbf{L}$  is a finite, semidistributive, breadth 2, big lattice, then  $\mathbf{L}$  contains a sublattice of the form  $(p \vee k)/p \cup k/(p \wedge k)$  such that  $\mathbf{FQ}(p, k)$  is infinite.*

Section 14 provides a set of sufficient conditions for  $\mathbf{FQ}(p, k)$  to be finite. The subsequent four sections prove that if one of those conditions fails in a finite, semidistributive, breadth 2 lattice  $\mathbf{L}$ , then  $\mathbf{L}$  contains a minimal big lattice from our list. This will prove Theorem 57.

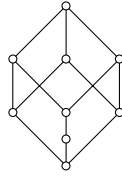
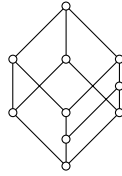
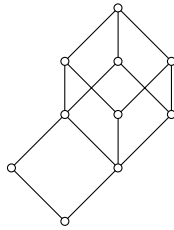
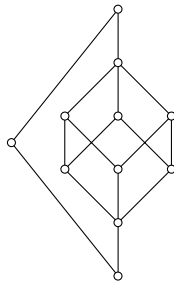
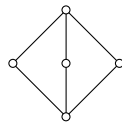
FIGURE 27.  $\mathbf{G}_1$ FIGURE 28.  $\mathbf{G}_2$ FIGURE 29.  $\mathbf{G}_3$ FIGURE 30.  $\mathbf{G}_4$ FIGURE 31.  $\mathbf{G}_5$



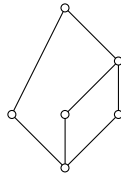

FIGURE 32.  $\mathbf{G}_6$

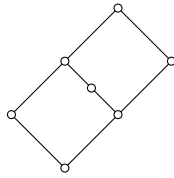

FIGURE 33.  $\mathbf{G}_7$

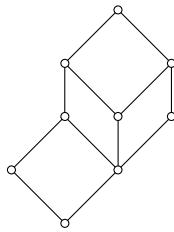

FIGURE 34.  $\mathbf{G}_8$

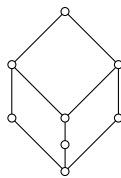

FIGURE 35.  $\mathbf{G}_9$

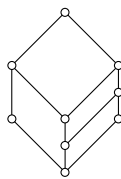
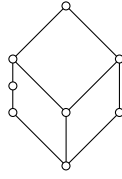
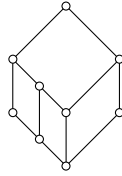
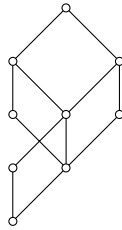
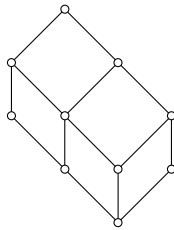
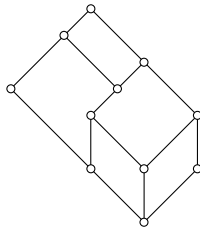

FIGURE 36.  $\mathbf{G}_{10}$

FIGURE 37.  $\mathbf{G}_{11}$ FIGURE 38.  $\mathbf{G}_{12}$ FIGURE 39.  $\mathbf{G}_{13}$ FIGURE 40.  $\mathbf{G}_{14}$ FIGURE 41.  $\mathbf{G}_{15}$

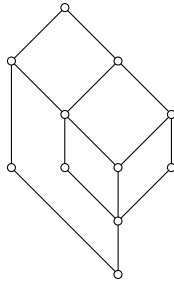

FIGURE 42.  $\mathbf{G}_{16}$

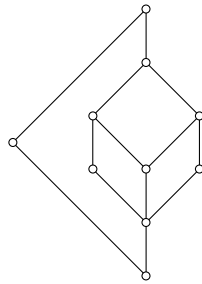

FIGURE 43.  $\mathbf{G}_{17}$

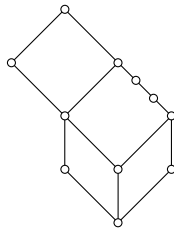

FIGURE 44.  $\mathbf{G}_{18}$

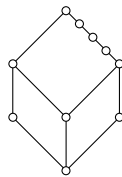

FIGURE 45.  $\mathbf{G}_{19}$

14. WHEN  $\mathbf{FQ}(p, k)$  IS FINITE

**Theorem 60.** *Let  $\mathbf{L}$  be a finite lattice which contains incomparable elements  $p$  and  $k$  such that  $L = (p \vee k)/p \cup k/(p \wedge k)$ . Assume that  $\mathbf{L}$  satisfies the following conditions.*

1.  $\mathbf{L} - \{p, k\}$  contains no 3 element antichain.
2. If  $\mathbf{L} - \{p, k\}$  contains elements  $x_0 < x_1$  and  $y_0 < y_1$ , then either
  - (a)  $x_0 \leq y_1$ , or
  - (b)  $y_0 \leq x_1$ , or
  - (c)  $p < x_0$  and  $x_1 \wedge (x_0 \vee y_1) = x_0$ , or
  - (d)  $p < y_0$  and  $y_1 \wedge (y_0 \vee x_1) = y_0$ , or
  - (e)  $x_1 < k$  and  $x_0 \vee (x_1 \wedge y_0) = x_1$ , or
  - (f)  $y_1 < k$  and  $y_0 \vee (y_1 \wedge x_0) = y_1$ .
3. If  $\mathbf{L} - \{p, k\}$  contains elements  $x$  and  $y_0 < y_1 < y_2 < y_3$ , then either
  - (a)  $x \leq y_3$ , or
  - (b)  $y_0 \leq x$ , or
  - (c)  $y_3 > p$  and  $y_3 \wedge (x \vee p) \leq y_2$ , or
  - (d)  $(x \vee p) \wedge (y_3 \vee p) = p$ , or
  - (e)  $y_0 < k$  and  $y_0 \vee (x \wedge k) \geq y_1$ , or
  - (f)  $(x \wedge k) \vee (y_0 \wedge k) = k$ .
4. If  $\mathbf{L} - \{p, k\}$  contains elements  $x$  and  $y_0 < y_1 < y_2 < y_3 < y_4$ , then either
  - (a)  $x \leq y_4$ , or
  - (b)  $y_0 \leq x$ , or
  - (c)  $y_3 > p$  and  $y_4 \wedge (x \vee y_3) = y_3$ , or
  - (d)  $y_1 < k$  and  $y_0 \vee (x \wedge y_1) = y_1$ .

Then the finitely presented lattice  $\mathbf{FQ}(p, k)$  is finite.

*Proof.* We begin by recalling the analogous result of Ježek and Slavík [6] for the finitely presented lattice generated by a join trivial partial lattice to be finite. (A partial lattice is *join trivial* if its presentation contains no proper joins.)

**Lemma 61.** *The free lattice over a finite join trivial partial lattice  $\mathbf{P}$  is finite if and only if  $\mathbf{P}$  satisfies the following conditions.*

1.  $\mathbf{P}$  contains no 3 element antichain.
2. If  $\mathbf{P}$  contains elements  $x_0 < x_1$  and  $y_0 < y_1$ , then either
  - (a)  $x_0 \leq y_1$ , or
  - (b)  $y_0 \leq x_1$ , or
  - (c) there exists an element  $s \in P$  such that  $s > y_1$  and  $x_1 \wedge s = x_0$ , or
  - (d) there exists an element  $t \in P$  such that  $t > x_1$  and  $y_1 \wedge t = y_0$ .
3. If  $\mathbf{P}$  contains elements  $x$  and  $y_0 < y_1 < y_2 < y_3$ , then either
  - (a)  $x \leq y_3$ , or
  - (b)  $y_0 \leq x$ , or
  - (c) there exists an element  $s \in P$  such that  $s \geq x$  and  $y_3 \wedge s \leq y_2$ .
4. If  $\mathbf{P}$  contains elements  $x$  and  $y_0 < y_1 < y_2 < y_3 < y_4$ , then either

- (a)  $x \leq y_4$ , or
- (b)  $y_0 \leq x$ , or
- (c) there exists an element  $s \in P$  such that  $s > x$  and  $y_4 \wedge s = y_3$ .

Our goal is to show that if  $\mathbf{L}$  satisfies the hypotheses of Theorem 60, then  $\mathbf{FQ}(p, k)$  is the union of two sublattices,  $\mathbf{A}$  and  $\mathbf{B}$ , where  $\mathbf{A}$  is generated by a subset of  $\mathbf{Q}(p, k)$  satisfying no nontrivial join relations and the hypotheses of Lemma 61, and  $\mathbf{B}$  is generated by a subset of  $\mathbf{Q}(p, k)$  satisfying no nontrivial meet relations and the hypotheses of the dual of Lemma 61. Now a finitely generated sublattice of a finitely presented lattice need not be finitely presented (Ralph McKenzie, private communication), but  $\mathbf{A}$  and  $\mathbf{B}$  will be homomorphic images of the corresponding finitely presented lattices, which are finite. Towards this end, note that the conditions of Theorem 60 translate as far as is possible the conditions of Lemma 61 and its dual into  $\mathbf{Q}(p, k)$ .

Let  $\mathbf{L}$  be a lattice satisfying the hypotheses of Theorem 60. Note that  $\mathbf{Q} = \mathbf{Q}(p, k)$  is isomorphic to  $\mathbf{L} - \{p, k\}$  as an ordered set. Since  $\mathbf{L} - \{p, k\}$  has width 2, by Dilworth's Theorem we can write it as the union of two chains,  $L - \{p, k\} = X \cup Y$ . Let

$$\begin{aligned} X_0 &= X \cap k/0 & X_1 &= X \cap 1/p \\ Y_0 &= Y \cap k/0 & Y_1 &= Y \cap 1/p. \end{aligned}$$

If say  $X_0 = \emptyset$ , then  $\mathbf{Q}$  is join trivial. In this case, conditions (1)–(4) reduce to the conditions of Ježek and Slavík [6] for a join trivial finitely presented lattice to be finite. Thus, by symmetry and duality, we may assume that  $X_0, X_1, Y_0$  and  $Y_1$  are all nonempty.

Let  $\hat{x}_0$  be the greatest element of  $X_0$ ,  $\hat{y}_0$  the greatest element of  $Y_0$ ,  $\hat{x}_1$  the least element of  $X_1$ , and  $\hat{y}_1$  the least element of  $Y_1$ . Note that  $\hat{x}_0 \vee \hat{y}_0 \leq k$  implies  $\hat{x}_0 \vee \hat{y}_0 \in \{\hat{x}_0, \hat{y}_0, k\}$ , and dually  $\hat{x}_1 \wedge \hat{y}_1 \in \{\hat{x}_1, \hat{y}_1, p\}$ . We may also assume that  $\hat{y}_1 \not\leq k$ , for otherwise  $\hat{y}_1 \geq p \vee k = 1_{\mathbf{L}}$ , and  $\mathbf{Q}$  would be meet trivial. Similarly  $\hat{x}_1 \not\leq k$ ,  $\hat{y}_0 \not\leq p$  and  $\hat{x}_0 \not\leq p$ .

Applying condition (2), we see that either  $\hat{x}_0 < \hat{y}_1$  or  $\hat{y}_0 < \hat{x}_1$ , w.l.o.g. the former. In that case  $\hat{x}_0 \vee \hat{y}_0 \leq \hat{y}_1 \wedge k < k$ . So  $\hat{x}_0 \vee \hat{y}_0 \in \{\hat{x}_0, \hat{y}_0\}$ . If  $\hat{y}_0 \leq \hat{x}_0$ , then every element of  $L - \{p, k\}$  is comparable to  $\hat{x}_0$ ; in that event  $\mathbf{FQ}(p, k)$  is the linear sum of  $q_{\hat{x}_0}/0$  and  $1/q_{\hat{x}_0}$ , with the bottom half meet trivial and finite, and the top half join trivial and finite. Thus we may assume that  $\hat{x}_0 < \hat{y}_0$ . Dually,  $\hat{x}_1 < \hat{y}_1$ .

We want to consider the structure of the middle interval  $\hat{y}_1/\hat{x}_0$ . Let

$$\begin{aligned} S &= \{s \in X_1 : s \leq \hat{y}_1\} \\ T &= \{T \in Y_0 : t \geq \hat{x}_0\}. \end{aligned}$$

Our situation is diagrammed in Figure 46(a). There are two cases to consider:

1.  $|S| = 1$  or  $|T| = 1$ ,
2.  $|S| \geq 2$  and  $|T| \geq 2$ .

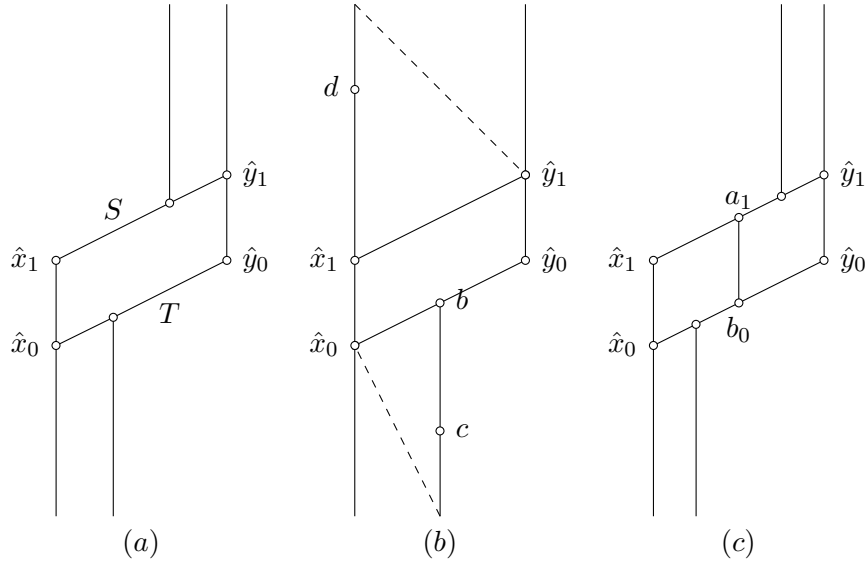
FIGURE 46.  $\mathbf{Q}(p, k)$ 

**Case 1.** Suppose say  $|S| = 1$  and  $|T| \geq 1$ . Let  $b$  be minimal in  $T$ . Let  $c$  be minimal in  $Y_0$  such that  $c \not\leq \hat{x}_0$ , so that  $c \vee \hat{x}_0 = b$ . Likewise, let  $d$  be maximal in  $Y_1$  such that  $d \not\geq \hat{y}_1$ , so that  $d \wedge \hat{y}_1 = \hat{x}_1$ . This situation is diagrammed in Figure 46(b). Now it is straightforward to prove that, for all  $w \in \mathbf{FQ}(p, k)$ , either

1.  $w \geq q_{\hat{x}_1} \wedge q_b$ ,  $w \in \text{Sg}(\{q_r : r \geq \hat{x}_1\} \cup \{q_s : b \leq s \leq \hat{y}_0\})$ , which is meet trivial, and  $w \leq q_d$  or  $w \geq q_b$ , or
2.  $w \leq q_b$ ,  $w \in \text{Sg}(\{q_t : t \leq b\} \cup \{q_{\hat{x}_1}\})$ , which is join trivial, and  $w \geq q_c$  or  $w \leq q_{\hat{x}_1}$ .

Indeed, let  $U$  denote the set of all  $w \in \mathbf{FQ}(p, k)$  satisfying either (1) or (2). The generators  $q_x$  ( $x \in L - \{p, k\}$ ) are contained in  $U$ , so it is required to show that  $U$  is closed under meet and join. The critical case is when say  $u$  satisfies (1) and  $v$  satisfies (2). If  $u \geq q_b$  or  $v \leq q_{\hat{x}_1}$ , then  $u \leq v$ , so w.l.o.g.  $u \leq q_d$  and  $v \geq q_c$ . Then

$$u \wedge v = q_d \wedge q_{\hat{y}_1} \wedge u \wedge v = q_{\hat{x}_1} \wedge q_b \wedge u \wedge v = q_{\hat{x}_1} \wedge v$$

so  $u \wedge v$  satisfies (2). Similarly,

$$u \vee v = q_c \vee q_{\hat{x}_1} \vee u \vee v = q_b \vee u$$

so  $u \vee v$  satisfies (1). Hence  $U = \mathbf{FQ}(p, k)$ . Thus if  $\mathbf{L}$  satisfies (1)–(4), then  $\mathbf{FQ}(p, k)$  is finite.

The case when  $|T| = 1$  is dual.

**Case 2.** Suppose  $|S| \geq 2$  and  $|T| \geq 2$ . Let  $a_0 = \hat{x}_1$  and  $a_1$  be the bottom two elements of  $S$ , and let  $b_0$  and  $b_1 = \hat{y}_0$  be the top two elements of  $T$ . By condition (2), either  $b_0 \leq a_1$  or  $a_1 \wedge (a_0 \vee b_1) = a_0$  or  $b_0 \vee (b_1 \wedge a_0) = b_1$ .

We claim that  $b_0 \leq a_1$  always holds. For suppose say  $a_1 \wedge (a_0 \vee b_1) = a_0$ . If  $a_0 \vee b_1 \in Y$ , then  $a_0 \vee b_1 \geq \hat{y}_1 \geq a_1$ , a contradiction. But if  $a_0 \vee b_1 \in X$ , then  $a_0 \vee b_1 \not\geq a_1$  implies  $a_0 \vee b_1 = a_0$ , whence  $b_1 \leq a_0$  and thus  $b_0 \leq a_1$ . Dually, the third possibility also implies  $b_0 \leq a_1$ . This situation is depicted in Figure 46(c).

In this case we prove that, for all  $w \in \mathbf{FQ}(p, k)$ , either

1.  $w \geq q_{\hat{y}_0} \wedge q_{a_1}$ ,  $w \in \text{Sg}(\{q_s : s > b_0\} \cup \{q_{\hat{x}_1}\})$ , which is meet trivial, and  $w \leq q_{\hat{y}_0}$  or  $w \geq q_{\hat{x}_1}$ , or
2.  $w \leq q_{\hat{x}_1} \vee q_{b_0}$ ,  $w \in \text{Sg}(\{q_t : t < a_1\} \cup \{q_{\hat{y}_0}\})$ , which is join trivial, and  $w \leq q_{\hat{y}_0}$  or  $w \geq q_{\hat{x}_1}$ .

Again let  $U$  denote the set of all  $w \in \mathbf{FQ}(p, k)$  satisfying either (1) or (2). The generators  $q_x$  ( $x \in L - \{p, k\}$ ) are contained in  $U$ , so we must show that  $U$  is closed under meet and join. The critical case is when say  $u$  satisfies (1) and  $v$  satisfies (2). If  $u \geq q_{\hat{x}_1}$  or  $v \leq q_{\hat{y}_0}$ , then  $u \leq v$ , so w.l.o.g.  $u \leq q_{\hat{y}_0}$  and  $v \geq q_{\hat{x}_1}$ . Then

$$u \vee v = q_{\hat{x}_1} \vee q_{b_0} \vee u \vee v = q_{\hat{x}_1} \vee u$$

so  $u \vee v$  satisfies (1). Dually,  $u \wedge v$  satisfies (2), and therefore  $U = \mathbf{FQ}(p, k)$ . Thus if  $\mathbf{L}$  satisfies (1)–(4), then  $\mathbf{FQ}(p, k)$  is finite.  $\square$

#### 15. CASES WITH $\mathbf{1} + \mathbf{1} + \mathbf{1} \leq \mathbf{Q}(p, k)$

First we consider the case when  $\mathbf{Q}(p, k)$  contains a 3 element antichain. As a matter of notation, we will henceforth use  $\mathbf{n}_1 + \cdots + \mathbf{n}_k$  to denote the ordered set which is a parallel sum (disjoint union) of chains.

**Theorem 62.** *Let  $\mathbf{L}$  be a finite, breadth 2, semidistributive lattice containing elements  $p, k$  such that  $p \vee k = \mathbf{1}_{\mathbf{L}}$ ,  $p \wedge k = \mathbf{0}_{\mathbf{L}}$  and  $L = \mathbf{1}/p \cup k/\mathbf{0}$ . If  $\mathbf{L} - \{p, k\}$  contains a 3 element antichain, then  $\mathbf{L}$  has a sublattice isomorphic to one of  $\mathbf{G}_{20}, \mathbf{G}_{21}, \mathbf{G}_{21}^d, \mathbf{G}_{22}, \mathbf{G}_{23}, \mathbf{G}_{23}^d, \mathbf{G}_{24}, \mathbf{G}_{24}^d, \mathbf{G}_{25}, \mathbf{G}_{25}^d, \mathbf{G}_{26}, \mathbf{G}_{26}^d, \mathbf{G}_{27}, \mathbf{G}_{27}^d, \mathbf{G}_{28}, \mathbf{G}_{28}^d, \mathbf{G}_{29}, \mathbf{G}_{30}, \mathbf{G}_{30}^d, \mathbf{G}_{31}, \mathbf{G}_{31}^d, \mathbf{G}_{32}, \mathbf{G}_{32}^d, \mathbf{G}_{33}, \mathbf{G}_{33}^d, \mathbf{G}_{34}, \mathbf{G}_{34}^d, \mathbf{G}_{35}, \mathbf{G}_{35}^d, \mathbf{G}_{36}, \mathbf{G}_{37}, \mathbf{G}_{38}, \mathbf{G}_{38}^d, \mathbf{G}_{39}, \mathbf{G}_{39}^d, \mathbf{G}_{65}, \mathbf{G}_{65}^d, \mathbf{G}_{73}, \mathbf{G}_{73}^d$ .*

(Note: The indexing of the  $\mathbf{G}_i$ 's is based on their generating configurations. The lattices  $\mathbf{G}_{65}$  and  $\mathbf{G}_{73}$ , which may appear out of order here, are so numbered because they are generated by  $\mathbf{1} + \mathbf{4}$  and  $\mathbf{1} + \mathbf{5}$ , respectively.)

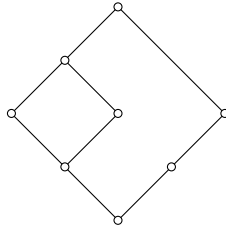
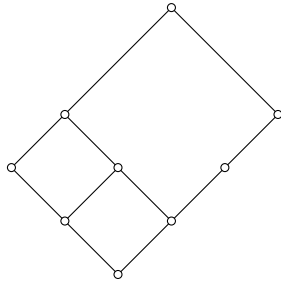
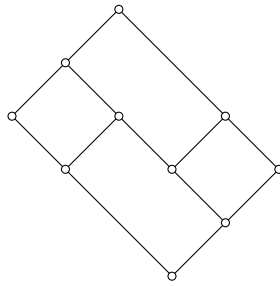
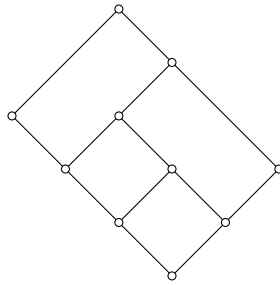
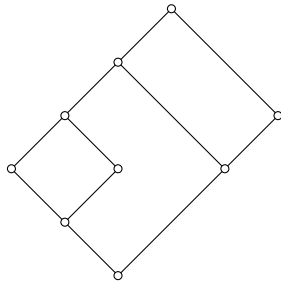
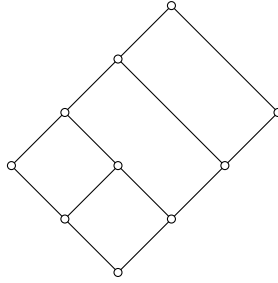
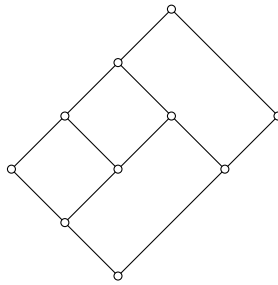
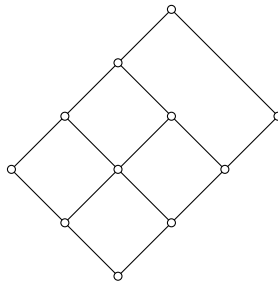

FIGURE 47.  $\mathbf{G}_{20}$

FIGURE 48.  $\mathbf{G}_{21}$ FIGURE 49.  $\mathbf{G}_{22}$ FIGURE 50.  $\mathbf{G}_{23}$ FIGURE 51.  $\mathbf{G}_{24}$

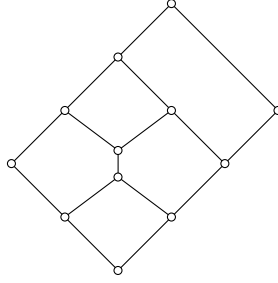
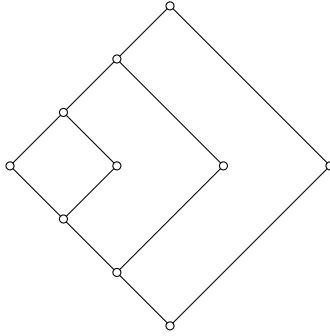
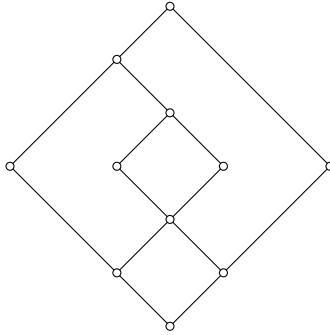

FIGURE 52.  $\mathbf{G}_{25}$ FIGURE 53.  $\mathbf{G}_{26}$ FIGURE 54.  $\mathbf{G}_{27}$ 

The proof divides into two subcases.

**Lemma 63.** *Let  $\mathbf{L}$  be a finite, semidistributive, breadth 2 lattice which contains incomparable elements  $p$  and  $k$ . Assume there exist  $p_1, p_2, t \in L$  such that*

1.  $p_1, p_2$  and  $t$  form a 3 element antichain,
2.  $p < p_1, p_2 < p \vee k$ ,
3.  $k > t > p \wedge k$ .

FIGURE 55.  $\mathbf{G}_{28}$ FIGURE 56.  $\mathbf{G}_{29}$ FIGURE 57.  $\mathbf{G}_{30}$ 

Then  $\mathbf{L}$  contains a sublattice isomorphic to one of  $\mathbf{G}_{20}$ ,  $\mathbf{G}_{21}$ ,  $\mathbf{G}_{22}$ ,  $\mathbf{G}_{23}$ ,  $\mathbf{G}_{24}$ ,  $\mathbf{G}_{25}$ ,  $\mathbf{G}_{26}$ ,  $\mathbf{G}_{27}$ ,  $\mathbf{G}_{28}$ , or one of their duals, and  $\mathbf{FQ}(p, k)$  is infinite. Thus  $\mathbf{L}$  is big.

*Proof.* Throughout we can restrict our attention to  $\text{Sg}(\{p_1, p_2, t, k\})$ , so that  $p \vee k = 1$  and  $p \wedge k = 0$ .

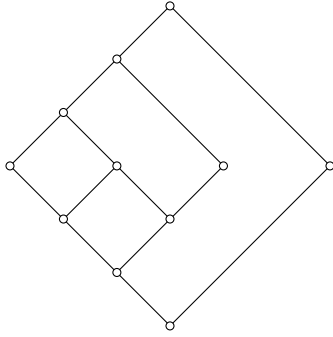
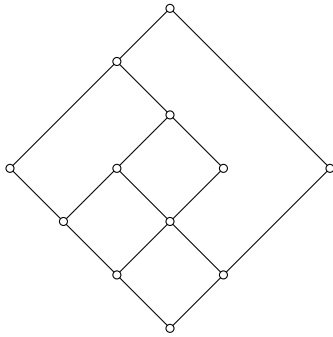
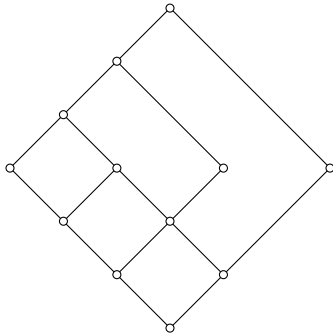
FIGURE 58.  $\mathbf{G}_{31}$ FIGURE 59.  $\mathbf{G}_{32}$ FIGURE 60.  $\mathbf{G}_{33}$ 

First, we need to show that we may assume that  $p_1 \wedge p_2 = p$  and  $p_1 \vee p_2 < p \vee k$ . If  $p_1 \vee p_2 = p \vee k$ , then by  $\text{SD}_\vee$  we have  $p \vee k = p \vee (p_1 \wedge k) \vee (p_2 \wedge k)$ , while  $\mathbf{L}$  has breadth 2 and no two of these terms join to  $p \vee k$ .

If  $p_1 \wedge p_2 > p$ , we would like to replace  $p$  by  $p_1 \wedge p_2$  and  $t$  by  $t \vee (p_1 \wedge p_2 \wedge k)$ . We can do this unless  $t \vee (p_1 \wedge p_2 \wedge k) = k$ , so assume that is the case. Since

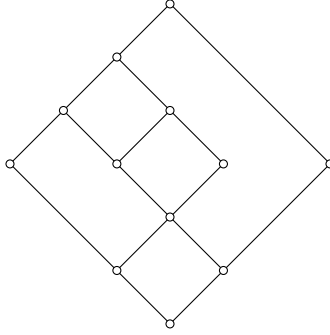
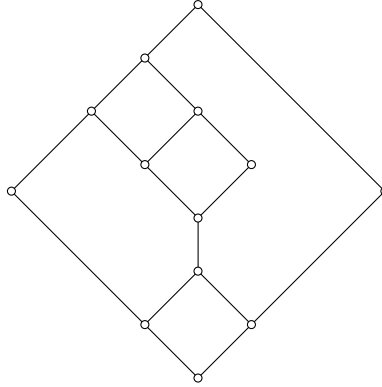
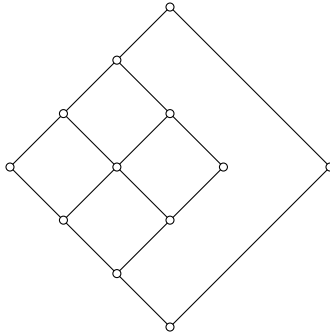
FIGURE 61.  $\mathbf{G}_{34}$ FIGURE 62.  $\mathbf{G}_{35}$ FIGURE 63.  $\mathbf{G}_{36}$ 

$\mathbf{L}$  has breadth 2, we have say  $p_1 \wedge p_2 \wedge k = p_1 \wedge k$ , whence  $p_1 \wedge k \leq p_2 \wedge k$  and  $k = t \vee (p_1 \wedge k)$ . In particular,  $p_2 \wedge k \not\leq t$ . If perchance  $p_2 \wedge k \not\leq p_1$ , then we have the dual of the desired situation:  $k = t \vee (p_2 \wedge k) > t, p_2 \wedge k > p \wedge k$  and  $p < p_1 < p \vee k$  with  $p_1, p_2 \wedge k, t$  a 3 element antichain. (Moreover,

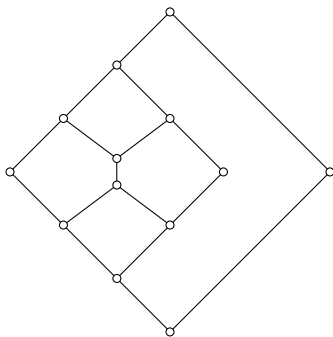

FIGURE 64.  $\mathbf{G}_{37}$

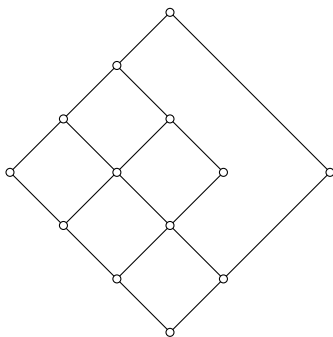

FIGURE 65.  $\mathbf{G}_{38}$

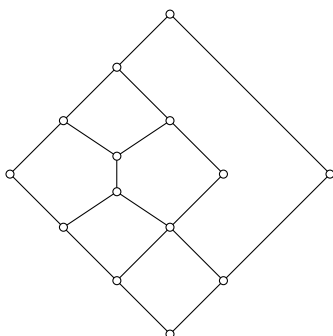

FIGURE 66.  $\mathbf{G}_{39}$

$p_2 \wedge t \neq p \wedge k$ , else by  $SD_{\wedge}$  we would have  $p \wedge k = p_2 \wedge k \wedge (p \vee t)$ , while no two of these terms meet to  $p$ .)

Thus we may assume  $p_2 \wedge k = p_1 \wedge k = (p_1 \vee p_2) \wedge k$ , again using  $SD_{\wedge}$ . Then we have the dual of the desired situation with  $m = p_1 \vee p_2 > p_1, p_2 > p_1 \wedge p_2 > m \wedge t$  and  $t < k < t \vee m$  and  $p_1, p_2, k$  a 3 element antichain.

Thus w.l.o.g.  $p_1 \wedge p_2 = p$  and  $p_1 \vee p_2 < p \vee k$ .

We may assume that  $p_1, p_2 \succ p$ . Let  $p'_1$  and  $p'_2$  be the canonical meetands of  $p$ , with  $p'_i \geq p_i$ . Since  $p'_1 \wedge p'_2 \wedge k = 0$  and  $\mathbf{L}$  has breadth 2, say  $p'_1 \wedge k = 0$ .

**Case 1.** Suppose  $p \vee t = 1$ . Then we can check that the hypotheses of Lemma 38 are satisfied with  $p'_1 \mapsto p_1, p'_2 \mapsto p_2$  and  $t \mapsto r$ , and hence one of  $\mathbf{G}_{20}, \mathbf{G}_{21}, \mathbf{G}_{22}, \mathbf{G}_{23}$  is a sublattice of  $\mathbf{L}$ .

So w.l.o.g.  $p \vee t < 1$ . We claim that  $p'_1 \vee p'_2 \vee t < 1$ , else by  $\text{SD}_\vee$

$$1 = p \vee k = p'_1 \vee p'_2 \vee t = p \vee t \vee (p'_2 \wedge k),$$

and no two of the right hand terms join to 1. Let  $l = p'_1 \vee p'_2 \vee t$ , and note for future reference that  $l = p_1 \vee p_2 \vee t$  (the join of the generators except  $k$ ).

Let  $t' = k \wedge l$ , and note  $t \leq t' < k$ , so that  $l = p'_1 \vee p'_2 \vee t'$ . In  $\text{Sg}(\{p_1, p_2, t, k\})$  we have

$$1 = p \vee k \text{ canonically}$$

$$\kappa(p) = k$$

$$\kappa(k) = l$$

$$k \wedge l = t'.$$

Replace  $t$  by  $t'$ , and drop the prime.

**Case 2.** If  $p \vee t = l$ , then we can check that Lemma 39 applies (with  $p \mapsto r$  and  $k \mapsto p$ ) and conclude that  $\mathbf{G}_{24}$  or  $\mathbf{G}_{25}$  is a sublattice of  $\mathbf{L}$ . So w.l.o.g.  $p \vee t < l$ .

**Case 3.** Suppose  $p_2 \wedge t = 0$ . Then  $p_2 \wedge k = p_2 \wedge k \wedge l = p_2 \wedge t = 0$ . Applying  $\text{SD}_\wedge$  to this and  $p_1 \wedge k = 0$ , we obtain  $(p_1 \vee p_2) \wedge k = 0$ . Now  $l = p_1 \vee p_2 \vee t$  and  $\mathbf{L}$  has breadth 2, while the preceding observation shows that  $p_1 \vee p_2 \neq l$ . Thus say  $p_1 \vee t = l$ , in which case  $p_2 \vee t \neq l$  else  $p \vee t = l$  by  $\text{SD}_\vee$ . Therefore  $p_2 \vee t \not\leq p_1$ .

We claim that  $p \vee t \geq p_2$ . For otherwise  $p = p_2 \wedge (p \vee t) = p_1 \wedge (p_2 \vee t)$  (using  $p_1, p_2 \succ p$  and the preceding paragraph). Then  $p = (p_1 \vee p_2) \wedge (p_1 \vee t) \wedge (p_2 \vee t)$  by  $\text{SD}_\wedge$ , while no two of these terms meet to  $p$ .

Now check that  $\{0, t, k, p, (p_1 \vee p_2) \wedge (p \vee t), p \vee t, p_1, p_1 \vee p_2, l, 1\}$  is a sublattice of  $\mathbf{L}$  isomorphic to  $\mathbf{G}_{26}$ .

Thus we may assume that  $p_2 \wedge t > 0$ . Since  $p_2 \succ p$  we have  $p_2 = p \vee (p_2 \wedge t)$ . Thus  $t \vee p < l = t \vee p_1 \vee p_2 = t \vee p_1$ .

**Case 4.** If  $p_1 \vee p_2 = l$ , then check that  $\{0, p_2 \wedge t, t, k, p, p_2, p \vee t, p_1, l, 1\}$  is a sublattice of  $\mathbf{L}$  isomorphic to  $\mathbf{G}_{23}$ .

**Case 5.** If  $p_1 \vee p_2 < l$ , then check that  $\{0, (p_1 \vee p_2) \wedge t, t, k, p, p \vee ((p_1 \vee p_2) \wedge t), (p_1 \vee p_2) \wedge (p \vee t), p \vee t, p_1, p_1 \vee p_2, l, 1\}$  is a sublattice of  $\mathbf{L}$  isomorphic to either  $\mathbf{G}_{27}$  or  $\mathbf{G}_{28}$ , depending on whether or not  $p \vee ((p_1 \vee p_2) \wedge t) = (p_1 \vee p_2) \wedge (p \vee t)$ .  $\square$

**Lemma 64.** *Let  $\mathbf{L}$  be a finite, semidistributive, breadth 2 lattice which contains incomparable elements  $p$  and  $k$ . Assume there exist  $x, y, z \in L$  such that*

1.  $x, y$  and  $z$  form a 3 element antichain,
2.  $p < x, y, z < p \vee k$ .

Then  $\mathbf{L}$  contains a sublattice isomorphic to one of  $\mathbf{G}_{29}, \mathbf{G}_{30}, \mathbf{G}_{31}, \mathbf{G}_{32}, \mathbf{G}_{33}, \mathbf{G}_{34}, \mathbf{G}_{35}, \mathbf{G}_{36}, \mathbf{G}_{37}, \mathbf{G}_{38}, \mathbf{G}_{39}, \mathbf{G}_{65}, \mathbf{G}_{73}$ , or one of their duals, or one of the lattices of Lemma 63, and  $\mathbf{FQ}(p, k)$  is infinite. Thus  $\mathbf{L}$  is big.

*Proof.* This time we can clearly assume that  $x \wedge y \wedge z = p$ , and confine our attention to  $\text{Sg}(\{x, y, z, k\})$ .

Since  $\mathbf{L}$  has breadth 2, we have  $x \vee y \vee z = x \vee z$  say. On the other hand, we cannot have  $x \vee y = x \vee z = y \vee z$ , else  $\text{SD}_\vee$  would yield  $x \vee y \vee z = (x \wedge y) \vee (x \wedge z) \vee (y \wedge z)$ , contradicting breadth 2. Thus say  $x \vee y < x \vee z$  (with  $y \vee z$  yet to be determined). Likewise, we cannot have  $x \vee z = p \vee k$ , else  $p \vee k = p \vee (x \wedge k) \vee (y \wedge k)$ , while no two of these terms join to the top. Summarizing, we may assume that  $x \vee y < x \vee z < p \vee k$ .

**Case 1:** Suppose  $y \vee z = x \vee z$ , in which case  $x \vee z = (x \wedge y) \vee z$ . Moreover, replacing  $z$  if necessary, we may assume that  $z \prec x \vee z$  without affecting the assumptions.

**Subcase 1a.** Assume  $x \wedge z = y \wedge z$ , in which case  $p = x \wedge y \wedge z = (x \vee y) \wedge z$ .

Now  $0 = p \wedge k = (x \vee y) \wedge z \wedge k$ . If  $z \wedge k \not\leq x \vee y$ , then we can take  $p_1 = x, p_2 = y, t = z \wedge k$  and apply Lemma 63. If  $z \wedge k = (x \vee y) \wedge k$ , then  $0 = (x \vee z) \wedge k$  by  $\text{SD}_\wedge$ , and  $\{0, k, p, z, x \wedge y, x, y, x \vee y, z \vee (x \wedge y), 1\}$  forms a sublattice of  $\mathbf{L}$  isomorphic to  $\mathbf{G}_{29}$ .

Thus we may assume  $z \wedge k = 0 < (x \vee y) \wedge k$ . It follows that  $x \wedge k \not\leq z$ , else  $0 = x \wedge k = z \wedge k = (x \vee z) \wedge k \geq (x \vee y) \wedge k$  by  $\text{SD}_\wedge$ , contrary to hypothesis. Likewise  $y \wedge k \not\leq z$ . Recall that  $x \vee z = y \vee z$ . If  $(x \vee z) \wedge k \not\leq y$ , then we can apply Lemma 63 with  $p_1 = y, p_2 = z$  and  $t = (x \vee z) \wedge k$ . Symmetrically, Lemma 63 applies if  $(y \vee z) \wedge k \not\leq x$ . Thus we may assume that  $x \wedge k = y \wedge k = (x \vee z) \wedge k$ . Note that  $x \wedge k \not\leq z \prec x \vee z$ , and so  $(x \wedge k) \vee z = x \vee z$ .

If  $p \vee ((x \vee y) \wedge k) = x \wedge y$ , then  $\{0, (x \vee y) \wedge k, k, p, x \wedge y, x, y, x \vee y, z, x \vee z, 1\}$  is a sublattice of  $\mathbf{L}$  isomorphic to  $\mathbf{G}_{30}$ . But if  $p \vee ((x \vee y) \wedge k) < x \wedge y$ , then  $\{0, (x \vee y) \wedge k, k, p, p \vee ((x \vee y) \wedge k), x \wedge y, x, x \vee y, z, x \vee z, 1\}$  is a sublattice of  $\mathbf{L}$  isomorphic to  $\mathbf{G}_{73}$ .

**Subcase 1b.** Assume  $x \wedge z = p < y \wedge z$ . (The case  $y \wedge z = p < x \wedge z$  is symmetric, while  $x \wedge y \neq p$  since  $x \vee z = (x \wedge y) \vee z$ .)

Let  $y' = (x \wedge y) \vee (z \wedge (x \vee (y \wedge z)))$ . Note that  $x \not\leq y'$ , else  $x \vee (y \wedge z) = (x \wedge y) \vee (z \wedge (x \vee (y \wedge z))) = (x \wedge y) \vee (y \wedge z) \leq y$  by  $\text{SD}_\vee$ . We have  $z \not\leq y'$  because  $y' \leq x \vee y$ , while  $y \wedge z \leq y'$  implies  $y' \not\leq x$  and  $x \wedge y \leq y'$  implies  $y' \not\leq z$ . Thus  $x, y', z$  is a 3 element antichain. Also note  $x \vee (y' \wedge z) = x \vee (y \wedge z)$ . We can replace  $y$  by  $y'$  without affecting the assumptions (the ones involving  $y$  are  $x \vee y < x \vee z = (x \wedge y) \vee z \succ z$  and  $y \wedge z > p$ ), and we gain  $z \wedge (x \vee (y' \wedge z)) \leq y'$  and  $(x \wedge y') \vee (y' \wedge z) = y'$ . Do so (for the remainder of Case 1) and drop the prime.

Note  $x \wedge z \wedge k = 0$  implies  $x \wedge k = 0$  or  $z \wedge k = 0$ . If both hold, then  $(x \vee z) \wedge k = 0$ , and  $\{0, p, x \wedge y, x, y \wedge z, y, x \vee y, z, x \vee z, k, 1\}$  is a sublattice of  $\mathbf{L}$  isomorphic to  $\mathbf{G}_{31}$ .

Next suppose  $z \wedge k = 0 < x \wedge k$ . As in Subcase 1a we can show that  $(x \vee z) \wedge k \leq x, y$  or else Lemma 63 applies. Hence we may assume that  $x \wedge k = y \wedge k = (x \vee z) \wedge k$ . Let  $l = x \wedge ((y \wedge z) \vee (x \wedge k))$ . If  $p \vee (x \wedge k) = l$ , then  $\{0, p, y \wedge z, z, x \wedge k, l, (y \wedge z) \vee (x \wedge k), x, x \vee y, x \vee z, k, 1\}$  is a sublattice of  $\mathbf{L}$  isomorphic to  $\mathbf{G}_{32}$ . But if  $p \vee (x \wedge k) < l$ , then  $\{0, p, y \wedge z, z, x \wedge k, p \vee (x \wedge k), l, (y \wedge z) \vee (x \wedge k), x \vee z, k, 1\}$  (omitting  $x$  and  $x \vee y$ ) is a sublattice of  $\mathbf{L}$  isomorphic to  $\mathbf{G}_{65}$ .

Finally, suppose  $x \wedge k = 0 < z \wedge k$ . This time we argue that  $(x \vee z) \wedge k \leq y, z$  or else Lemma 63 applies. Hence we may assume that  $y \wedge k = z \wedge k = (x \vee z) \wedge k$ . Let  $m = z \wedge (x \vee (z \wedge k))$ . If  $p \vee (z \wedge k) = m$ , then  $\{0, z \wedge k, k, p, m, z, x \wedge y, (x \wedge y) \vee (z \wedge k), x, x \vee (z \wedge k), x \vee z, 1\}$  is a sublattice of  $\mathbf{L}$  isomorphic to  $\mathbf{G}_{33}$ . If not, then  $p \vee (z \wedge k) < m$ , and we have more work to do.

Note that  $m = z \wedge (x \vee (y \wedge k)) \leq z \wedge (x \vee y) = z \wedge (x \vee (y \wedge z)) = y \wedge z$ , and hence  $m \vee (x \wedge y) \leq y$ . If perchance  $m \leq (x \wedge y) \vee (z \wedge k)$ , then  $\{0, p, x \wedge y, x, z \wedge k, p \vee (z \wedge k), m, (x \wedge y) \vee (z \wedge k), x \vee (z \wedge k), k, 1\}$  (omitting  $z$  and  $x \vee z$ ) is a sublattice of  $\mathbf{L}$  isomorphic to  $\mathbf{G}_{65}$ . But if  $m \not\leq (x \wedge y) \vee (z \wedge k)$ , let  $n = z \wedge ((x \wedge y) \vee (z \wedge k))$ ; then  $\{p, n, m, z, x \wedge y, (x \wedge y) \vee (z \wedge k), m \vee (x \wedge y), x, x \vee (z \wedge k), x \vee z\}$  is a sublattice of  $\mathbf{L}$  isomorphic to  $\mathbf{G}_{23}$ .

This finishes Case 1.

**Case 2:** Suppose  $y \vee z < x \vee z$  (and still  $x \vee y < x \vee z < p \vee k$ ). Choose  $x', y'$  such that  $x \leq x' \prec x \vee y$  and  $z \leq z' \prec y \vee z$ . Set  $y' = (x \vee y) \wedge (y \vee z)$ , and note that  $x' \wedge z' < y'$ . Set  $p' = x' \wedge z'$ . Now it is straightforward to check that  $x', y', z'$  form a 3 element antichain, and the hypotheses for this case are still satisfied by these elements,  $p'$  and  $k$ . So, dropping the primes, we may assume that  $x \prec x \vee y, z \prec y \vee z, (x \vee y) \wedge (y \vee z) = y$ , and  $x \wedge z = p$ . Also note that the roles of  $x$  and  $z$  are symmetric at this point.

We cannot have both  $x \wedge y = p$  and  $y \wedge z = p$ , else  $p = y \wedge (x \vee z) = y$  by  $\text{SD}_\wedge$ . Also note that  $(x \vee z) \wedge k$  is below at least 2 of the elements  $x, y, z$  or else Lemma 63 applies.

**Subcase 2a.** Assume  $y \wedge z = p < x \wedge y$ . (The case  $x \wedge y = p < y \wedge z$  is symmetric.) Since  $x \wedge z = p$ , we obtain  $(x \vee y) \wedge z = p$  by  $\text{SD}_\wedge$ .

If  $(x \vee z) \wedge k = 0$ , then  $\{0, k, p, x \wedge y, x, y, x \vee y, z, y \vee z, x \vee z, 1\}$  is a sublattice of  $\mathbf{L}$  isomorphic to  $\mathbf{G}_{31}^d$ .

So assume  $(x \vee z) \wedge k > 0$ . Then  $(x \vee z) \wedge k \not\leq p = x \wedge z = y \wedge z$ , so  $(x \vee z) \wedge k \leq x \wedge y$ . Then  $\{0, (x \vee z) \wedge k, k, p, p \vee ((x \vee z) \wedge k), x \wedge y, x, y, x \vee y, z, y \vee z, x \vee z, 1\}$  is a sublattice of  $\mathbf{L}$  isomorphic to  $\mathbf{G}_{34}$  or  $\mathbf{G}_{35}$ , depending on whether or not  $p \vee ((x \vee z) \wedge k) = x \wedge y$ .

**Subcase 2b.** Assume  $x \wedge y > p$  and  $y \wedge z > p$ .

If  $(x \vee z) \wedge k = 0$ , then  $\{0, k, p, x \wedge y, x, y \wedge z, (x \wedge y) \vee (y \wedge z), y, x \vee y, z, y \vee z, x \vee z, 1\}$  is a sublattice of  $\mathbf{L}$  isomorphic to  $\mathbf{G}_{36}$  or  $\mathbf{G}_{37}$ , depending on whether or not  $(x \wedge y) \vee (y \wedge z) = y$ .



So suppose  $(x \vee z) \wedge k > 0$ . Now  $(x \vee z) \wedge k$  is below two of the elements  $x, y, z$ , but not below  $p = x \wedge z$ , so by symmetry we may assume  $(x \vee z) \wedge k \leq y \wedge z$ . Then  $(x \vee z) \wedge k = y \wedge k = z \wedge k$ , while  $x \wedge k \leq x \wedge z \wedge k = p \wedge k = 0$ .

If  $p \vee (z \wedge k) = y \wedge z$ , then  $\{0, z \wedge k, k, p, y \wedge z, z, x \wedge y, (x \wedge y) \vee (y \wedge z), y, y \vee z, x, x \vee y, x \vee z, 1\}$  is a sublattice of  $\mathbf{L}$  isomorphic to  $\mathbf{G}_{38}$  or  $\mathbf{G}_{39}$ , depending on whether or not  $(x \wedge y) \vee (y \wedge z) = y$ .

Thus we may assume  $p \vee (z \wedge k) < y \wedge z$ . If perchance  $y \wedge z \leq (x \wedge y) \vee (z \wedge k)$ , then  $\{0, p, x \wedge y, x, z \wedge k, p \vee (z \wedge k), y \wedge z, (x \wedge y) \vee (z \wedge k), x \vee y, k, 1\}$  is a sublattice of  $\mathbf{L}$  isomorphic to  $\mathbf{G}_{65}$ . But if  $y \wedge z \not\leq (x \wedge y) \vee (z \wedge k)$ , then let  $y' = (x \wedge y) \vee (z \wedge k)$  and  $z' = y \wedge z$ . Then  $x, y', z'$  is a triple satisfying the hypotheses of Subcase 1b (with  $x$  and  $z$  interchanged), and in fact we get  $\mathbf{G}_{65}$  or  $\mathbf{G}_{32}$  as a sublattice of  $\mathbf{L}$ .

This finishes Case 2 and the proof of the lemma.  $\square$

## 16. CASES WITH $\mathbf{2} + \mathbf{2} \leq \mathbf{Q}(p, k)$

Next we consider the case when  $\mathbf{Q}(p, k)$  contains a subset isomorphic to  $\mathbf{2} + \mathbf{2}$  violating the conditions of Theorem 60(2).

**Theorem 65.** *Let  $\mathbf{L}$  be a finite, breadth 2, semidistributive lattice containing elements  $p, k$  such that  $p \vee k = 1_{\mathbf{L}}$ ,  $p \wedge k = 0_{\mathbf{L}}$  and  $L = 1/p \cup k/0$ . If  $\mathbf{L} - \{p, k\}$  contains elements  $x_0 < x_1$  and  $y_0 < y_1$  satisfying*

1.  $x_0 \not\leq y_1$ ,
2.  $y_0 \not\leq x_1$ ,
3.  $p < x_0$  implies  $x_1 \wedge (x_0 \vee y_1) > x_0$ ,
4.  $p < y_0$  implies  $y_1 \wedge (y_0 \vee x_1) > y_0$ ,
5.  $x_1 < k$  implies  $x_0 \vee (x_1 \wedge y_0) < x_1$ ,
6.  $y_1 < k$  implies  $y_0 \vee (y_1 \wedge x_0) < y_1$ ,

then  $\mathbf{L}$  has a sublattice isomorphic to one of  $\mathbf{G}_{40}, \mathbf{G}_{40}^d, \mathbf{G}_{41}, \mathbf{G}_{42}, \mathbf{G}_{42}^d, \mathbf{G}_{43}, \mathbf{G}_{43}^d, \mathbf{G}_{44}, \mathbf{G}_{44}^d, \mathbf{G}_{45}, \mathbf{G}_{46}, \mathbf{G}_{46}^d, \mathbf{G}_{47}, \mathbf{G}_{47}^d, \mathbf{G}_{48}, \mathbf{G}_{48}^d, \mathbf{G}_{49}, \mathbf{G}_{50}, \mathbf{G}_{50}^d, \mathbf{G}_{51}, \mathbf{G}_{51}^d, \mathbf{G}_{52}, \mathbf{G}_{53}, \mathbf{G}_{53}^d, \mathbf{G}_{54}$ , or one of the previous lattices.

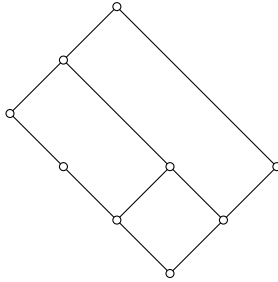
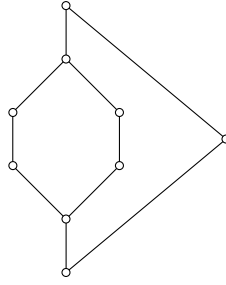
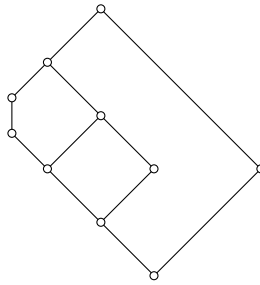
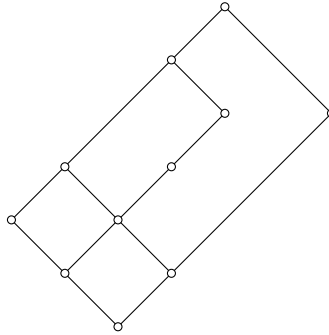

FIGURE 67.  $\mathbf{G}_{40}$

FIGURE 68.  $\mathbf{G}_{41}$ FIGURE 69.  $\mathbf{G}_{42}$ FIGURE 70.  $\mathbf{G}_{43}$ 

The proof divides into three subcases.

**Lemma 66.** *Let  $\mathbf{L}$  be a finite, semidistributive, breadth 2 lattice which contains incomparable elements  $p$  and  $k$ . Assume there exist  $x_0, x_1, y_1 \in L$  such that*

1.  $p < x_0 < x_1 < p \vee k$ ,
2.  $p < y_1 < p \vee k$ ,
3.  $x_0 \not\leq y_1$ ,
4.  $k \wedge y_1 \not\leq x_1$ ,

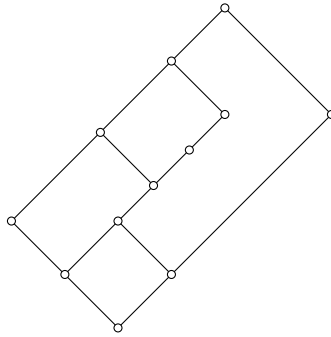

FIGURE 71.  $\mathbf{G}_{44}$

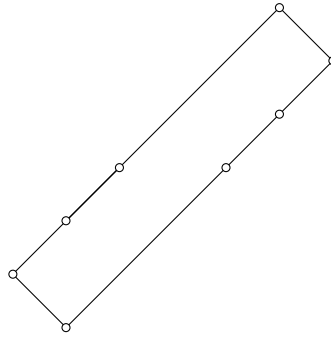

FIGURE 72.  $\mathbf{G}_{45}$

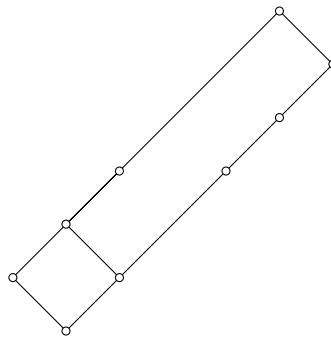
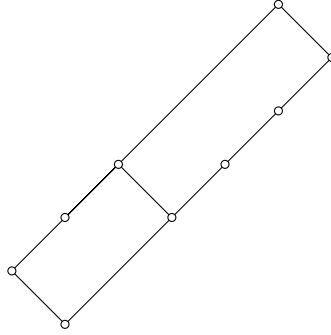
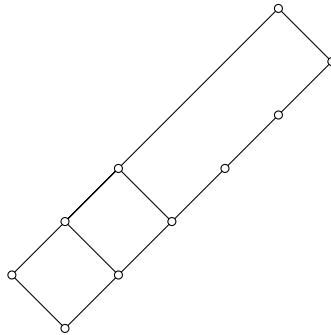
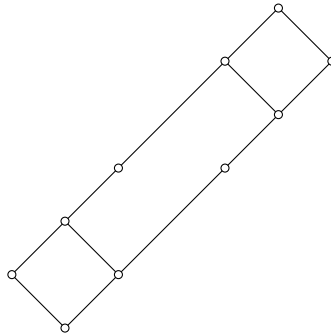

FIGURE 73.  $\mathbf{G}_{46}$

5.  $x_1 \wedge (x_0 \vee y_1) > x_0$ .

Then  $\mathbf{L}$  contains a sublattice isomorphic to  $\mathbf{G}_{40}$ , or one of the previous lattices, and  $\mathbf{FQ}(p, k)$  is infinite. Thus  $\mathbf{L}$  is big.

*Proof.* Let  $y_0 = k \wedge y_1$ , and replace  $x_1$  by  $x'_1 = x_1 \wedge (x_0 \vee y_1)$ , so that  $x_1 \leq x_0 \vee y_1$ . Note that  $x_1 \vee y_1 < p \vee k$ , for if  $x_1 \vee y_1 = p \vee k$  then

FIGURE 74.  $\mathbf{G}_{47}$ FIGURE 75.  $\mathbf{G}_{48}$ FIGURE 76.  $\mathbf{G}_{49}$ 

$p \vee k = p \vee (x_1 \wedge k) \vee (y_1 \wedge k)$  by  $\text{SD}_\vee$ , while no two of these terms join to  $p \vee k$ .

Now  $x_0 \vee y_0 \geq x_1$  or  $y_1$ , or else  $x_1, y_1, x_0 \vee y_0$  is a 3 element antichain. Likewise,  $x_1 \wedge y_1 \leq x_0$  (since  $x_1 \wedge y_1 \not\leq k$ ).

If perchance  $x_1 \vee y_0 \not\geq y_1$ , then  $x_0 \vee y_0 \geq x_1$ . In that case, let  $y'_1 = p \vee y_0$ , and note that the hypotheses are preserved and  $x_1 \vee y_0 \geq y'_1$ . Thus we may assume that  $x_1 \vee y_0 \geq y_1$ .

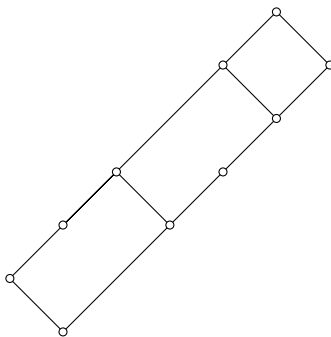

FIGURE 77.  $\mathbf{G}_{50}$

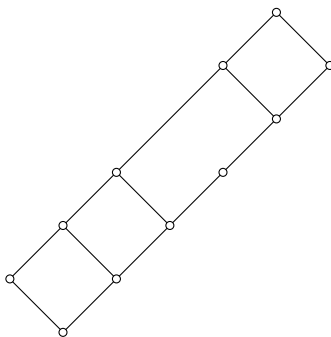

FIGURE 78.  $\mathbf{G}_{51}$

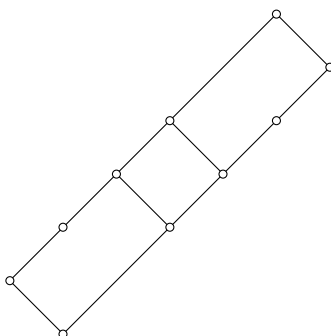
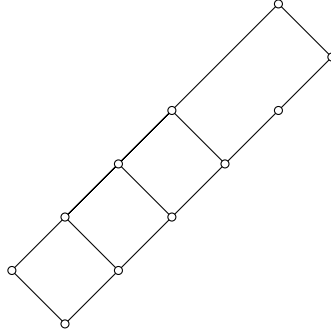
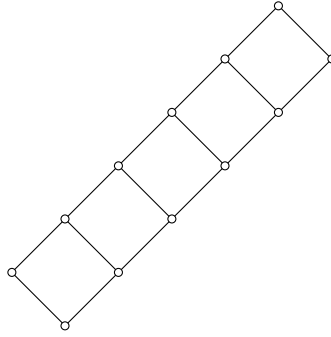

FIGURE 79.  $\mathbf{G}_{52}$

Now we have  $x_1 \vee y_1 = x_0 \vee y_1 = x_1 \vee y_0$ , whence by  $\text{SD}_\vee$   $x_1 \vee y_1 = x_0 \vee y_0 \vee (x_1 \wedge y_1) = x_0 \vee y_0$ . Moreover, we may assume that  $k \wedge (x_1 \vee y_1) = k \wedge y_1 = y_0$ , or else  $x_1, y_1, (x_1 \vee y_1) \wedge k$  is a 3 element antichain.

Finally, we can check that  $\{x_1 \wedge k, y_0, k, x_1 \wedge y_1, y_0 \vee (x_1 \wedge y_1), x_0, x_1, x_0 \vee y_0, 1\}$  forms a sublattice of  $\mathbf{L}$  isomorphic to  $\mathbf{G}_{40}$ .  $\square$

FIGURE 80.  $\mathbf{G}_{53}$ FIGURE 81.  $\mathbf{G}_{54}$ 

**Lemma 67.** *Let  $\mathbf{L}$  be a finite, semidistributive, breadth 2 lattice which contains incomparable elements  $p$  and  $k$ . Assume there exist  $x_0, x_1, y_0, y_1 \in L$  such that*

1.  $p < x_0 < x_1 < p \vee k$ ,
2.  $p < y_0 < y_1 < p \vee k$ ,
3.  $x_0 \not\leq y_1$ ,
4.  $y_0 \not\leq x_1$ ,
5.  $x_1 \wedge (x_0 \vee y_1) > x_0$ ,
6.  $y_1 \wedge (y_0 \vee x_1) > y_0$ .

*Then  $\mathbf{L}$  contains a sublattice isomorphic to one of  $\mathbf{G}_{41}, \mathbf{G}_{42}, \mathbf{G}_{43}, \mathbf{G}_{44}$ , or one of the previous lattices, and  $\mathbf{FQ}(p, k)$  is infinite. Thus  $\mathbf{L}$  is big.*

*Proof.* As before,  $x_1 \vee y_1 < p \vee k$  by  $\text{SD}_\vee$  and the breadth 2 property. W.l.o.g.  $x_1 \leq x_0 \vee y_1$  and  $y_1 \leq y_0 \vee x_1$ . Moreover, by Lemma 66, we may assume that  $k \wedge x_1 \leq y_1$  and  $k \wedge y_1 \leq x_1$ , so that  $k \wedge x_1 = k \wedge y_1 = k \wedge (x_1 \vee y_1)$ .

Again we see that  $x_0 \vee y_0 \geq x_1$  or  $y_1$ , say the former, or else we get a 3 element antichain. It follows that  $y_1 \leq y_0 \vee x_1 = x_0 \vee y_0$  also holds.

Consider  $x_1 \wedge y_1$ , which is below  $x_0$  or  $y_0$ , or else we get a 3 element antichain. If it is below both, then  $\{k \wedge x_1, k, x_1 \wedge y_1, x_0, x_1, y_0, y_1, x_0 \vee y_0, 1\}$  forms a sublattice of  $\mathbf{L}$  isomorphic to  $\mathbf{G}_{41}$ .

So suppose say  $x_1 \wedge y_1 \leq y_0$  but  $x_1 \wedge y_1 \not\leq x_0$ . Consider  $k \wedge x_1 = k \wedge y_1$ , which is below  $y_0$  and may or may not be below  $x_0$ . If  $k \wedge x_1 \leq x_0$ , then set  $x'_1 = x_0 \vee (x_1 \wedge y_1)$ . Since  $x_0 < x'_1 \leq x_1$ , we see that  $\{k \wedge x_1, k, x_0 \wedge y_1, x_1 \wedge y_1, y_0, y_1, x_0, x'_1, x_0 \vee y_0, 1\}$  is a sublattice of  $\mathbf{L}$  isomorphic to  $\mathbf{G}_{42}$ . If, however,  $k \wedge x_1 \not\leq x_0$ , then set  $x''_1 = x_0 \vee (k \wedge x_1)$ . In this case  $\{k \wedge x_0, k \wedge x_1, k, x_0 \wedge y_1, (x_0 \wedge y_1) \vee (k \wedge x_1), x''_1 \wedge y_1, y_0, y_1, x_0, x''_1, x_0 \vee y_0, 1\}$  is a sublattice of  $\mathbf{L}$  isomorphic to  $\mathbf{G}_{43}$  or  $\mathbf{G}_{44}$ , depending on whether or not  $(x_0 \wedge y_1) \vee (k \wedge x_1) = x''_1 \wedge y_1$ .  $\square$

**Lemma 68.** *Let  $\mathbf{L}$  be a finite, semidistributive, breadth 2 lattice which contains incomparable elements  $p$  and  $k$ . Assume there exist  $x_0, x_1, y_0, y_1 \in L$  such that*

1.  $p < x_0 < x_1 < p \vee k$ ,
2.  $p \wedge k < y_0 < y_1 < k$ ,
3.  $y_0 \not\leq x_1$ ,
4.  $x_1 \wedge (x_0 \vee y_1) > x_0$ ,
5.  $y_0 \vee (y_1 \wedge x_0) < y_1$ .

*Then  $\mathbf{L}$  contains a sublattice isomorphic to one of  $\mathbf{G}_{45}, \mathbf{G}_{46}, \mathbf{G}_{47}, \mathbf{G}_{48}, \mathbf{G}_{49}, \mathbf{G}_{50}, \mathbf{G}_{51}, \mathbf{G}_{52}, \mathbf{G}_{53}, \mathbf{G}_{54}$ , or one of their duals, or one of the previous lattices, and  $\mathbf{FQ}(p, k)$  is infinite. Thus  $\mathbf{L}$  is big.*

*Proof.* Replacing  $x_1$  by  $x'_1 = x_1 \wedge (x_0 \vee y_1)$  and  $y_0$  by  $y'_0 = y_0 \vee (y_1 \wedge x_0)$ , we may assume that  $x_1 \leq x_0 \vee y_1$  and  $y_0 \geq y_1 \wedge x_0$ . Check that the hypotheses are preserved, and drop the primes.

If  $x_0 \vee y_0 \not\leq x_1$ , then  $x_1, x_0 \vee y_0, y_1$  form a 3 element antichain. (Note that if  $y_1 \leq x_0 \vee y_0$ , then  $x_1 \leq x_0 \vee y_1 = x_0 \vee y_0$ .) Thus we may assume that  $x_0 \vee y_0 \geq x_1$ , and dually  $x_1 \wedge y_1 \leq y_0$ .

In fact, we can assume  $p \vee y_0 \geq x_1$  and dually  $k \wedge x_1 \leq y_0$ . For if  $p \vee y_0 \not\geq x_1$ , then  $x_0, x_1$  and  $y'_1 = p \vee y_0$  satisfy the hypotheses of Lemma 66. (That  $x_0 \not\leq y'_1$  and  $x_0 \vee y'_1 > x_1$  both follow from  $x_0 \vee y_0 \geq x_1$ .)

The rest of the proof divides into 16 subcases, according to whether or not

- A.  $k \wedge (p \vee y_0) > y_1$ , or
- B.  $k \wedge (p \vee y_0) = y_1$ , or
- C.  $p \vee y_0 \not\leq y_1$  and  $k \wedge (p \vee y_1) > y_1$ , or
- D.  $p \vee y_0 \not\leq y_1$  and  $k \wedge (p \vee y_1) = y_1$ ,

and dually,

- a.  $p \vee (k \wedge x_1) < x_0$ , or
- b.  $p \vee (k \wedge x_1) = x_0$ , or
- c.  $k \wedge x_1 \not\leq x_0$  and  $p \vee (k \wedge x_0) < x_0$ , or
- d.  $k \wedge x_1 \not\leq x_0$  and  $p \vee (k \wedge x_0) = x_0$ .

We will do the first 4 subcases, where (A) holds; the remaining 12 subcases are similar.

**Subcase Aa.** If  $k \wedge (p \vee y_0) > y_1$  and  $p \vee (k \wedge x_1) < x_0$ , then  $\{k \wedge x_1, y_0, y_1, k \wedge (p \vee y_0), p \vee (k \wedge x_1), x_0, x_1, p \vee y_0\}$  forms a sublattice of  $\mathbf{L}$  isomorphic to  $\mathbf{G}_{45}$ .

**Subcase Ab.** If  $k \wedge (p \vee y_0) > y_1$  and  $p \vee (k \wedge x_1) = x_0$ , then  $\{p \wedge k, k \wedge x_1, y_0, y_1, k \wedge (p \vee y_0), p, x_0, x_1, p \vee y_0\}$  forms a sublattice of  $\mathbf{L}$  isomorphic to  $\mathbf{G}_{46}$ .

**Subcase Ac.** If  $k \wedge (p \vee y_0) > y_1$  and  $k \wedge x_1 \not\leq x_0$  and  $p \vee (k \wedge x_0) < x_0$ , then  $\{k \wedge x_0, k \wedge x_1, y_0, y_1, k \wedge (p \vee y_0), p \vee (k \wedge x_0), x_0, p \vee (k \wedge x_1), p \vee y_0\}$  forms a sublattice of  $\mathbf{L}$  isomorphic to  $\mathbf{G}_{47}$ .

**Subcase Ad.** If  $k \wedge (p \vee y_0) > y_1$  and  $k \wedge x_1 \not\leq x_0$  and  $p \vee (k \wedge x_0) = x_0$ , then  $\{p \wedge k, k \wedge x_0, k \wedge x_1, y_0, y_1, k \wedge (p \vee y_0), p, x_0, p \vee (k \wedge x_1), p \vee y_0\}$  forms a sublattice of  $\mathbf{L}$  isomorphic to  $\mathbf{G}_{48}$ .  $\square$

### 17. CASES WITH $\mathbf{1} + \mathbf{4} \leq \mathbf{Q}(p, k)$

Next we consider the case when  $\mathbf{Q}(p, k)$  contains a subset isomorphic to  $\mathbf{1} + \mathbf{4}$  violating the conditions of Theorem 60(3).

**Theorem 69.** *Let  $\mathbf{L}$  be a finite, breadth 2, semidistributive lattice containing elements  $p, k$  such that  $p \vee k = \mathbf{1}_{\mathbf{L}}$ ,  $p \wedge k = \mathbf{0}_{\mathbf{L}}$  and  $L = \mathbf{1}/p \cup k/\mathbf{0}$ . If  $\mathbf{L} - \{p, k\}$  contains elements  $x$  and  $y_0 < y_1 < y_2 < y_3$  satisfying*

1.  $y_0 \not\leq x$ ,
2.  $x \not\leq y_3$ ,
3.  $y_3 > p$  implies  $y_3 \wedge (x \vee p) \not\leq y_2$ ,
4.  $(x \vee p) \wedge (y_3 \vee p) > p$ ,
5.  $y_0 < k$  implies  $y_0 \vee (x \wedge k) \not\leq y_1$ ,
6.  $(x \wedge k) \vee (y_0 \wedge k) < k$ ,

*then  $\mathbf{L}$  has a sublattice isomorphic to one of  $\mathbf{G}_{55}, \mathbf{G}_{56}, \mathbf{G}_{56}^d, \mathbf{G}_{57}, \mathbf{G}_{57}^d, \mathbf{G}_{58}, \mathbf{G}_{58}^d, \mathbf{G}_{59}, \mathbf{G}_{59}^d, \mathbf{G}_{60}, \mathbf{G}_{60}^d, \mathbf{G}_{61}, \mathbf{G}_{61}^d, \mathbf{G}_{62}, \mathbf{G}_{62}^d, \mathbf{G}_{63}, \mathbf{G}_{63}^d, \mathbf{G}_{64}, \mathbf{G}_{64}^d, \mathbf{G}_{65}, \mathbf{G}_{65}^d, \mathbf{G}_{66}, \mathbf{G}_{66}^d, \mathbf{G}_{67}, \mathbf{G}_{68}, \mathbf{G}_{68}^d, \mathbf{G}_{69}, \mathbf{G}_{69}^d$ , or one of the previous lattices.*

The proof divides into five subcases. By duality we may assume that the element  $x$  is above  $p$ .

**Lemma 70.** *Let  $\mathbf{L}$  be a finite, semidistributive, breadth 2 lattice which contains incomparable elements  $p$  and  $k$ . Assume there exist  $x, y_0, y_1, y_2, y_3 \in L$  such that*

1.  $p < x < p \vee k$ ,
2.  $p \wedge k < y_0 < y_1 < y_2 < y_3 < k$ ,
3.  $y_0 \not\leq x$ ,
4.  $x \wedge (y_3 \vee p) > p$ ,
5.  $y_0 \vee (x \wedge k) \not\leq y_1$ .



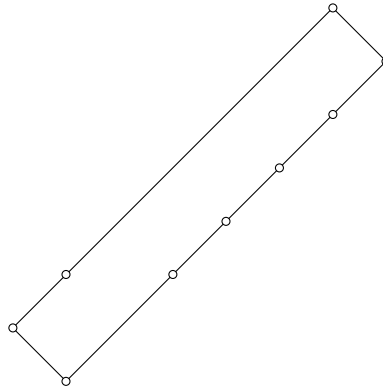

FIGURE 82.  $\mathbf{G}_{55}$

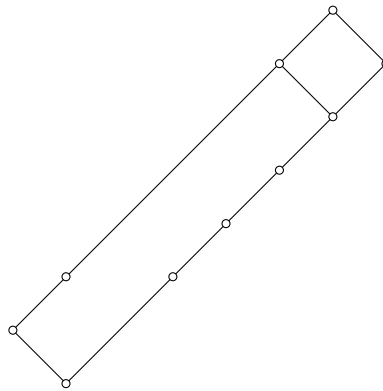

FIGURE 83.  $\mathbf{G}_{56}$

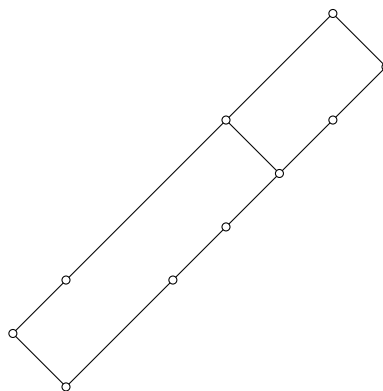
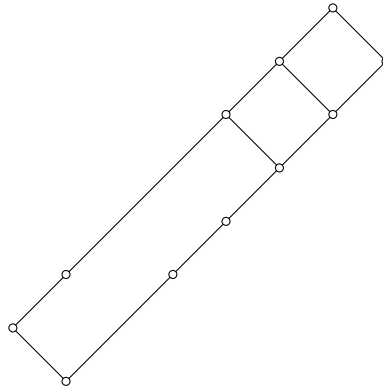
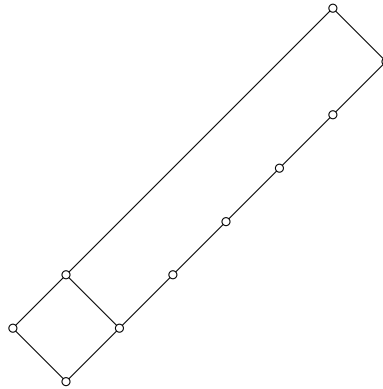
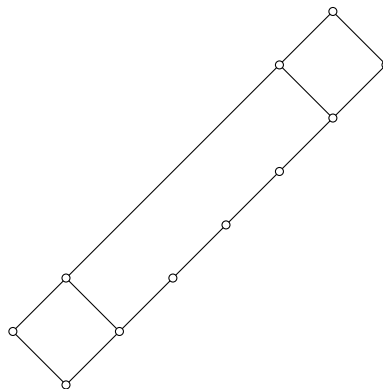

FIGURE 84.  $\mathbf{G}_{57}$

FIGURE 85.  $\mathbf{G}_{58}$ FIGURE 86.  $\mathbf{G}_{59}$ FIGURE 87.  $\mathbf{G}_{60}$

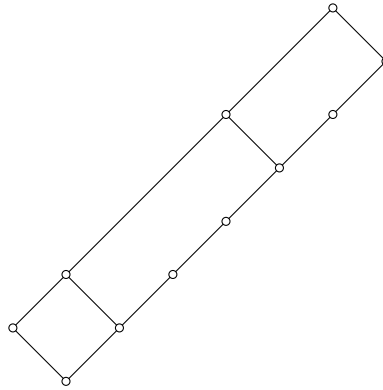

FIGURE 88.  $\mathbf{G}_{61}$

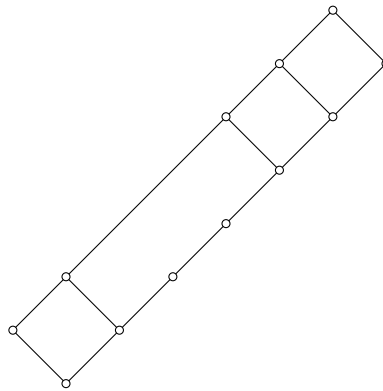

FIGURE 89.  $\mathbf{G}_{62}$

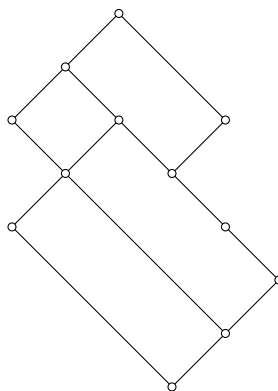
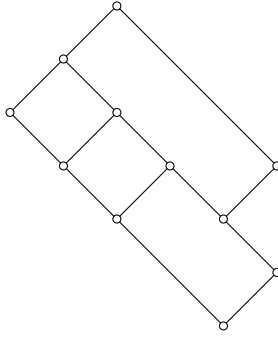
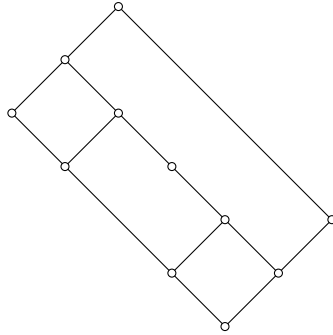
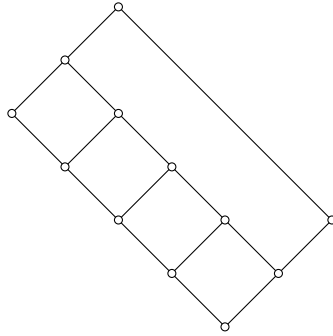

FIGURE 90.  $\mathbf{G}_{63}$

FIGURE 91.  $\mathbf{G}_{64}$ FIGURE 92.  $\mathbf{G}_{65}$ FIGURE 93.  $\mathbf{G}_{66}$ 

Then  $\mathbf{L}$  contains a sublattice isomorphic to one of  $\mathbf{G}_{55}$ ,  $\mathbf{G}_{56}$ ,  $\mathbf{G}_{57}$ ,  $\mathbf{G}_{58}$ ,  $\mathbf{G}_{59}$ ,  $\mathbf{G}_{60}$ ,  $\mathbf{G}_{61}$ ,  $\mathbf{G}_{62}$ , or one of the previous lattices, and  $\mathbf{FQ}(p, k)$  is infinite. Thus  $\mathbf{L}$  is big.

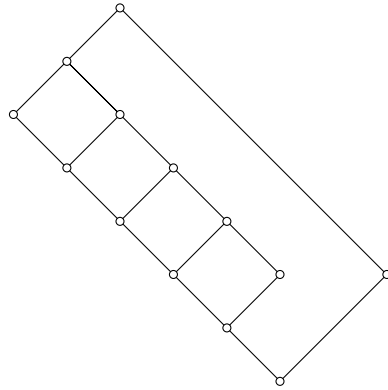

FIGURE 94.  $\mathbf{G}_{67}$

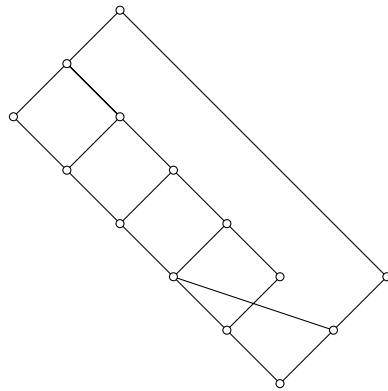

FIGURE 95.  $\mathbf{G}_{68}$

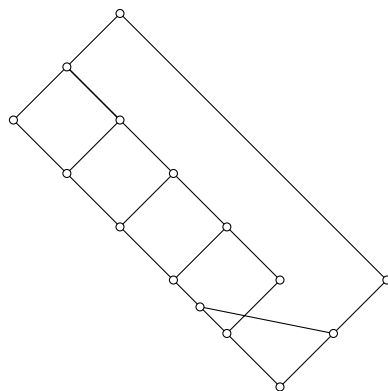

FIGURE 96.  $\mathbf{G}_{69}$

*Proof.* W.l.o.g. we may assume  $x \leq y_3 \vee p$ . In fact, with this assumption, if  $x \not\leq y_0 \vee p$ , then  $x, y_0 \vee p, y_3$  is a 3 element antichain. Thus we may assume that  $x \leq y_0 \vee p$ .

Likewise, if  $y_0 \vee (x \wedge k) \not\leq y_1$ , then  $x, y_0 \vee (x \wedge k), y_1$  is a 3 element antichain, so we may assume  $y'_0 = y_0 \vee (x \wedge k) \leq y_1$ . Replacing  $y_0$  if necessary,  $x \wedge k \leq y_0$ .

If  $y_0 \vee p \not\geq y_2$ , then  $x, y_0 \vee p, y_2, y_3$  satisfy the hypotheses of Lemma 68. Thus we may assume  $y_0 \vee p \geq y_2$ .

The rest of the proof divides into 4 cases, with 2 subcases each, according to whether or not

- A.  $p \vee (x \wedge k) < x$ , or
- B.  $p \vee (x \wedge k) = x$ ,

and

- a.  $k \wedge (y_0 \vee p) > y_2$ , or
- b.  $k \wedge (y_0 \vee p) = y_2$ .

We will do the first 2 cases, where (A) holds; the remaining 2 cases are similar.

**Case Aa.** If  $p \vee (x \wedge k) < x$  and  $k \wedge (y_0 \vee p) > y_2$ , we consider whether

- i.  $k \wedge (y_0 \vee p) > y_3$ , or
- ii.  $k \wedge (y_0 \vee p) \not> y_3$ .

If (i) holds, then  $\{x \wedge k, y_0, y_1, y_2, y_3, k \wedge (y_0 \vee p), p \vee (k \wedge x), x, y_0 \vee p\}$  forms a sublattice of  $\mathbf{L}$  isomorphic to  $\mathbf{G}_{55}$ . If (ii) holds, then  $\{x \wedge k, y_0, y_1, y_2, k \wedge (y_0 \vee p), k, p \vee (k \wedge x), x, y_0 \vee p, p \vee k\}$  forms a sublattice of  $\mathbf{L}$  isomorphic to  $\mathbf{G}_{56}$ .

**Case Ab.** If  $p \vee (x \wedge k) < x$  and  $k \wedge (y_0 \vee p) = y_2$ , we consider whether

- i.  $k \wedge (y_3 \vee p) > y_3$ , or
- ii.  $k \wedge (y_3 \vee p) = y_3$ .

If (i) holds, then  $\{x \wedge k, y_0, y_1, y_2, y_3, k \wedge (y_3 \vee p), p \vee (k \wedge x), x, y_0 \vee p, y_3 \vee p\}$  forms a sublattice of  $\mathbf{L}$  isomorphic to  $\mathbf{G}_{57}$ . If (ii) holds, then  $\{x \wedge k, y_0, y_1, y_2, y_3, k, p \vee (k \wedge x), x, y_0 \vee p, y_3 \vee p, p \vee k\}$  forms a sublattice of  $\mathbf{L}$  isomorphic to  $\mathbf{G}_{58}$ .  $\square$

**Lemma 71.** *Let  $\mathbf{L}$  be a finite, semidistributive, breadth 2 lattice which contains incomparable elements  $p$  and  $k$ . Assume there exist  $x, y_0 < y_1 < y_2 < y_3 \in L$  such that*

1.  $p < x, y_3 < p \vee k$ ,
2.  $p \wedge k < y_0 < y_1 < y_2 < k$ ,
3.  $y_0 \not\leq x$ ,
4.  $x \not\leq y_3$ ,
5.  $x \wedge y_3 > p$ ,
6.  $y_0 \vee (x \wedge k) \not\leq y_1$ .

*Then  $\mathbf{L}$  contains a sublattice isomorphic to  $\mathbf{G}_{63}$ , or one of the previous lattices, and  $\mathbf{FQ}(p, k)$  is infinite. Thus  $\mathbf{L}$  is big.*

*Proof.* Note that  $x \vee y_3 < p \vee k$  by  $\text{SD}_\vee$  and the breadth 2 property. As in the previous lemma, we may assume that  $x \wedge k \leq y_0$ .

Moreover, we may assume that  $k \wedge (x \vee y_3) \leq p \vee y_0$ , or else  $x, k \wedge (x \vee y_3), p \vee y_0$  is a 3 element antichain. It follows that  $y_2 < p \vee y_0 \leq y_3$ .

If  $p \vee (x \wedge k) < x \wedge y_3$ , then we can apply Lemma 68 with  $p \mapsto y_0, k \mapsto x, x_0 \mapsto y_1, x_1 \mapsto y_2, y_0 \mapsto p \vee (x \wedge k), y_1 \mapsto x \wedge y_3$ . Thus w.l.o.g.  $p \vee (x \wedge k) = x \wedge y_3$ , whence we also get  $x \wedge k > p \wedge k$ .

Now we can check that  $\{p \wedge k, x \wedge k, y_0, y_1, k \wedge (x \vee y_0), k, p, p \vee (x \wedge k), p \vee y_0, x, y_0 \vee x, p \vee k\}$  is a sublattice of  $\mathbf{L}$  isomorphic to  $\mathbf{G}_{63}$ .  $\square$

**Lemma 72.** *Let  $\mathbf{L}$  be a finite, semidistributive, breadth 2 lattice which contains incomparable elements  $p$  and  $k$ . Assume there exist  $x, y_0 < y_1 < y_2 < y_3 \in L$  such that*

1.  $p < x < p \vee k$  and  $p < y_2 < y_3 < p \vee k$ ,
2.  $p \wedge k < y_0 < y_1 < k$ ,
3.  $y_0 \not\leq x$ ,
4.  $x \not\leq y_3$ ,
5.  $x \wedge y_3 \not\leq y_2$ ,
6.  $y_0 \vee (x \wedge k) \not\leq y_1$ .

*Then  $\mathbf{L}$  contains a sublattice isomorphic to  $\mathbf{G}_{64}$ , or one of the previous lattices, and  $\mathbf{FQ}(p, k)$  is infinite. Thus  $\mathbf{L}$  is big.*

*Proof.* Note that  $x \vee y_3 < p \vee k$  by  $\text{SD}_\vee$  and the breadth 2 property. As before, we may assume that  $x \wedge k \leq y_0$ .

We can assume that  $y_1 \leq p \vee y_0$ , or else  $x, p \vee y_0, y_1$  is a 3 element antichain. Likewise,  $k \wedge (x \vee y_0) \leq p \vee y_0$ , or else  $x, k \wedge (x \vee y_0), p \vee y_0$  is a 3 element antichain. Note that  $y_1 \leq k \wedge (x \vee y_0)$ .

Now we can check that  $\{x \wedge k, y_0, k \wedge (x \vee y_0), k, x \wedge y_2, y_0 \vee (x \wedge y_2), x \wedge y_3, y_0 \vee (x \wedge y_3), x, x \vee y_0, p \vee k\}$  is a sublattice of  $\mathbf{L}$  isomorphic to  $\mathbf{G}_{64}$ .  $\square$

**Lemma 73.** *Let  $\mathbf{L}$  be a finite, semidistributive, breadth 2 lattice which contains incomparable elements  $p$  and  $k$ . Assume there exist  $x, y_0 < y_1 < y_2 < y_3 \in L$  such that*

1.  $p < x < p \vee k$  and  $p < y_1 < y_2 < y_3 < p \vee k$ ,
2.  $p \wedge k < y_0 < k$ ,
3.  $y_0 \not\leq x$ ,
4.  $x \not\leq y_3$ ,
5.  $x \wedge y_3 \not\leq y_2$ ,

*Then  $\mathbf{L}$  contains a sublattice isomorphic to  $\mathbf{G}_{65}$  or  $\mathbf{G}_{66}$ , or one of the previous lattices, and  $\mathbf{FQ}(p, k)$  is infinite. Thus  $\mathbf{L}$  is big.*

*Proof.* Note that  $y_0 \vee (x \wedge k) < k$ , or else  $p \vee k = p \vee y_0 \vee (x \wedge k)$  would violate the breadth 2 property.

As usual we get  $x \vee y_3 < p \vee k$  and  $x \wedge k \leq y_0$ . Moreover, we may assume that  $k \wedge (y_0 \vee x) \leq y_1$ , or else  $x, k \wedge (y_0 \vee x), y_1$  is a 3 element antichain. Replacing  $y_0$  if necessary, we may assume that  $k \wedge (y_0 \vee x) = y_0$ .

Likewise,  $y_2 \leq y_0 \vee (x \wedge y_3)$ , or else  $x, y_0 \vee (x \wedge y_3), y_2$  is a 3 element antichain.

Now check that if  $x \wedge y_2 \leq y_1$ , then  $\{x \wedge k, y_0, k, x \wedge y_1, y_0 \vee (x \wedge y_1), y_2, x \wedge y_3, y_0 \vee (x \wedge y_3), x, x \vee y_0, p \vee k\}$  is a sublattice of  $\mathbf{L}$  isomorphic to  $\mathbf{G}_{65}$ . (This lattice appeared in Lemma 64, but properly belongs here.)

But if  $x \wedge y_2 \not\leq y_1$ , then  $\{x \wedge k, y_0, k, x \wedge y_1, y_0 \vee (x \wedge y_1), x \wedge y_2, y_0 \vee (x \wedge y_2), x \wedge y_3, y_0 \vee (x \wedge y_3), x, x \vee y_0, p \vee k\}$  is a sublattice of  $\mathbf{L}$  isomorphic to  $\mathbf{G}_{66}$ .  $\square$

**Lemma 74.** *Let  $\mathbf{L}$  be a finite, semidistributive, breadth 2 lattice which contains incomparable elements  $p$  and  $k$ . Assume there exist  $x, y_0 < y_1 < y_2 < y_3 \in L$  such that*

1.  $p < x < p \vee k$ ,
2.  $p < y_0 < y_1 < y_2 < y_3 < p \vee k$ ,
3.  $y_0 \not\leq x$ ,
4.  $x \not\leq y_3$ ,
5.  $x \wedge y_3 \not\leq y_2$ ,

*Then  $\mathbf{L}$  contains a sublattice isomorphic to  $\mathbf{G}_{67}$ ,  $\mathbf{G}_{68}$ ,  $\mathbf{G}_{69}$ , or one of the previous lattices, and  $\mathbf{FQ}(p, k)$  is infinite. Thus  $\mathbf{L}$  is big.*

*Proof.* Note that  $(x \wedge y_0) \vee (x \wedge k) < k$ , or else  $p \vee k = p \vee (x \wedge y_0) \vee (x \wedge k)$  would violate the breadth 2 property. As usual we get  $x \vee y_3 < p \vee k$  (but not necessarily  $x \wedge k \leq y_0$ ).

W.l.o.g.  $y_0 \wedge k \leq x$ , or else we can apply Lemma 73. Using this, we can assume that  $y_3 \wedge k \leq x$ , or else  $x, y_0, y_3 \wedge k$  is a 3 element antichain.

We may assume that  $x \wedge k \leq y_3$ , or else Lemma 66 applies with  $x_0 \mapsto y_0, x_1 \mapsto y_3, y_1 \mapsto x$ . Then w.l.o.g. we may assume that  $x \wedge k \leq y_2$ , for if not we can replace  $y_3$  by  $y'_3 = y_2 \vee (x \wedge k)$ .

Next we claim that  $y_2 \leq y_1 \vee (y_3 \wedge x)$ , or else  $x, y_2, y_1 \vee (y_3 \wedge x)$  is a 3 element antichain. So we may assume that  $y_2 \wedge x \not\leq y_1$ , or else  $\{x \wedge k, k, y_2 \wedge x, y_3 \wedge x, x, y_1, y_2, y_2 \vee (y_3 \wedge x), y_2 \vee x, p \vee k\}$  is a sublattice of  $\mathbf{L}$  isomorphic to  $\mathbf{G}_{42}^d$ .

Similarly  $y_1 \leq y_0 \vee (y_2 \wedge x)$ , or else  $x, y_1, y_0 \vee (y_2 \wedge x)$  is a 3 element antichain. Thus we may assume that  $x \wedge k \leq y_1$ , or else we can apply Lemma 66 with  $x_0 \mapsto y_0, x_1 \mapsto y_1, y_1 \mapsto x$ . It follows exactly as above that  $y_1 \wedge x \not\leq y_0$ , or else  $\mathbf{G}_{42}^d$  is a sublattice of  $\mathbf{L}$ .

Now if it happens that  $x \wedge k \leq y_0$ , then  $\{x \wedge k, k, y_0 \wedge x, y_0, y_1 \wedge x, y_0 \vee (y_1 \wedge x), y_2 \wedge x, y_0 \vee (y_2 \wedge x), y_3 \wedge x, y_0 \vee (y_3 \wedge x), x, y_0 \vee x, p \vee k\}$  forms a sublattice of  $\mathbf{L}$  isomorphic to  $\mathbf{G}_{67}$ .

On the other hand, if  $x \wedge k \not\leq y_0$ , then  $\{y_0 \wedge k, x \wedge k, k, y_0 \wedge x, y_0, (y_0 \wedge x) \vee (x \wedge k), y_1 \wedge x, y_0 \vee (y_1 \wedge x), y_2 \wedge x, y_0 \vee (y_2 \wedge x), y_3 \wedge x, y_0 \vee (y_3 \wedge x), x, y_0 \vee x, p \vee k\}$  forms a sublattice of  $\mathbf{L}$  isomorphic to either  $\mathbf{G}_{68}$  or  $\mathbf{G}_{69}$ , depending on whether or not  $(y_0 \wedge x) \vee (x \wedge k) = y_1 \wedge x$ .  $\square$



18. CASES WITH  $\mathbf{1} + \mathbf{5} \leq \mathbf{Q}(p, k)$ 

Finally we consider the case when  $\mathbf{Q}(p, k)$  contains a subset isomorphic to  $\mathbf{1} + \mathbf{5}$  violating the conditions of Theorem 60(4).

**Theorem 75.** *Let  $\mathbf{L}$  be a finite, breadth 2, semidistributive lattice containing elements  $p, k$  such that  $p \vee k = \mathbf{1}_{\mathbf{L}}$ ,  $p \wedge k = \mathbf{0}_{\mathbf{L}}$  and  $L = \mathbf{1}/p \cup k/\mathbf{0}$ . If  $\mathbf{L} - \{p, k\}$  contains elements  $x$  and  $y_0 < y_1 < y_2 < y_3 < y_4$  satisfying*

1.  $y_0 \not\leq x$ ,
2.  $x \not\leq y_4$ ,
3.  $y_3 > p$  implies  $y_4 \wedge (x \vee y_3) > y_3$ ,
4.  $y_1 < k$  implies  $y_0 \vee (x \wedge y_1) < y_1$ ,

*then  $\mathbf{L}$  has a sublattice isomorphic to one of  $\mathbf{G}_{70}$ ,  $\mathbf{G}_{70}^d$ ,  $\mathbf{G}_{71}$ ,  $\mathbf{G}_{71}^d$ ,  $\mathbf{G}_{72}$ ,  $\mathbf{G}_{72}^d$ ,  $\mathbf{G}_{73}$ ,  $\mathbf{G}_{73}^d$ ,  $\mathbf{G}_{74}$ ,  $\mathbf{G}_{75}$ ,  $\mathbf{G}_{75}^d$ ,  $\mathbf{G}_{76}$ ,  $\mathbf{G}_{76}^d$ ,  $\mathbf{G}_{77}$ ,  $\mathbf{G}_{77}^d$ ,  $\mathbf{G}_{78}$ ,  $\mathbf{G}_{78}^d$ ,  $\mathbf{G}_{79}$ ,  $\mathbf{G}_{79}^d$ ,  $\mathbf{G}_{80}$ ,  $\mathbf{G}_{80}^d$ ,  $\mathbf{G}_{81}$ ,  $\mathbf{G}_{81}^d$ , or one of the previous lattices.*

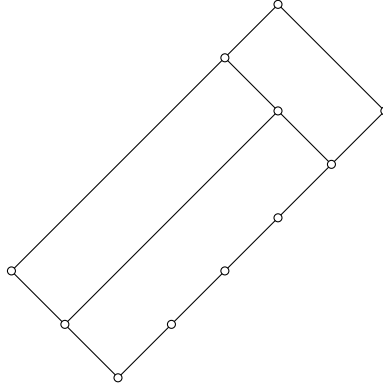
FIGURE 97.  $\mathbf{G}_{70}$ 

The division into subcases is somewhat complicated, being based on our desire to avoid the lattices from the case  $\mathbf{1} + \mathbf{4}$ . We can assume that the elements  $x, y_0, y_1, y_2, y_4$  fail the hypothesis of Theorem 69, and therefore must satisfy

- C3.  $y_4 > p$  and  $y_4 \wedge x \leq y_2$ , or
- D3.  $x \wedge (y_4 \vee p) = p$ , or
- E3.  $y_0 < k$  and  $y_0 \vee (x \wedge k) \geq y_1$ , or
- F3.  $(x \wedge k) \vee (y_0 \wedge k) = k$ .

Likewise, we can assume that the elements  $x, y_0, y_2, y_3, y_4$  satisfy

- C1.  $y_4 > p$  and  $y_4 \wedge x \leq y_3$ , or
- D1.  $x \wedge (y_4 \vee p) = p$ , or
- E1.  $y_0 < k$  and  $y_0 \vee (x \wedge k) \geq y_2$ , or

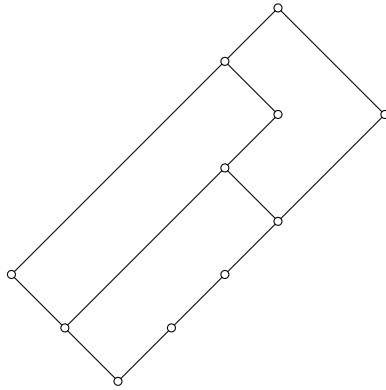
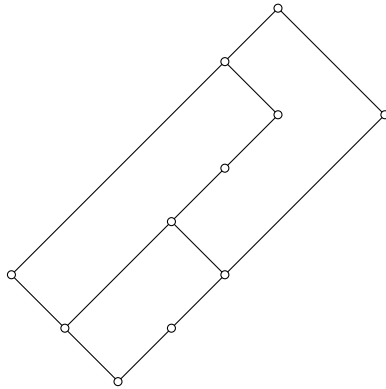
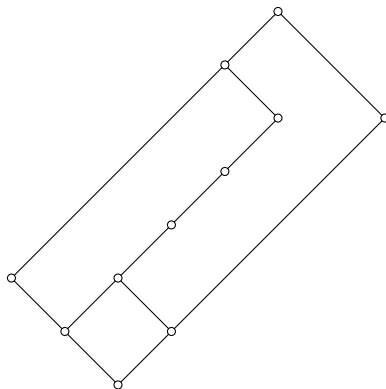
FIGURE 98.  $\mathbf{G}_{71}$ FIGURE 99.  $\mathbf{G}_{72}$ FIGURE 100.  $\mathbf{G}_{73}$

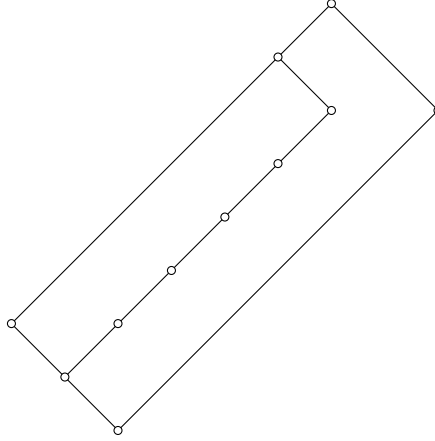
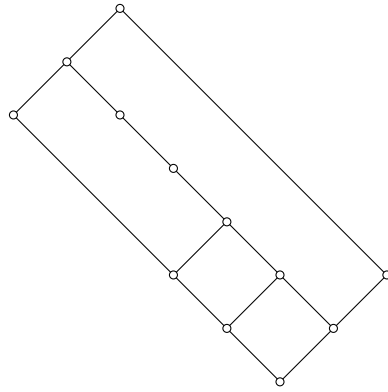
FIGURE 101.  $\mathbf{G}_{74}$ FIGURE 102.  $\mathbf{G}_{75}$ 

$$F1. (x \wedge k) \vee (y_0 \wedge k) = k.$$

We could write three more such sets of conditions (largely overlapping), but these are the ones we will use. By duality we may assume that  $x \geq p$ .

Our first case covers  $D3=D1$ .

**Lemma 76.** *Let  $\mathbf{L}$  be a finite, semidistributive, breadth 2 lattice which contains incomparable elements  $p$  and  $k$ . Assume there exist  $x, y_0 < y_1 < y_2 < y_3 < y_4 \in p \vee k/p \cup k/p \wedge k$  such that*

1.  $p < x < p \vee k$ ,
2.  $y_0 \not\leq x$ ,
3.  $x \not\leq y_4$ ,
4.  $y_3 > p$  implies  $y_4 \wedge (x \vee y_3) > y_3$ ,
5.  $y_1 < k$  implies  $y_0 \vee (x \wedge y_1) < y_1$ ,
6.  $x \wedge (y_4 \vee p) = p$ .

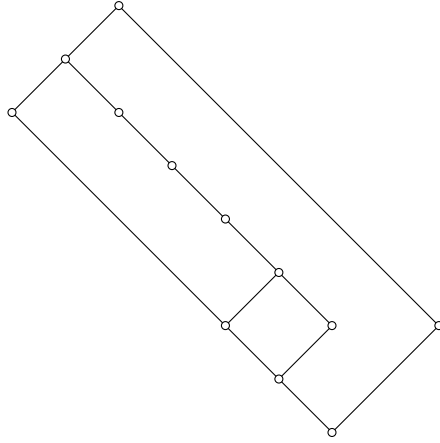
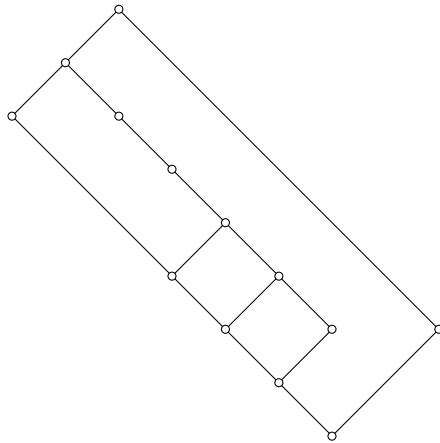
FIGURE 103.  $\mathbf{G}_{76}$ FIGURE 104.  $\mathbf{G}_{77}$ 

Then  $\mathbf{L}$  contains a sublattice isomorphic to one of  $\mathbf{G}_{70}$ ,  $\mathbf{G}_{71}$ ,  $\mathbf{G}_{72}$ ,  $\mathbf{G}_{73}$ , or  $\mathbf{G}_{74}$ , or one of the previous lattices, and  $\mathbf{FQ}(p, k)$  is infinite. Thus  $\mathbf{L}$  is big.

*Proof.* First, we claim that we may assume  $y_4 \geq p$ . If  $y_3 \geq p$ , this follows. If  $y_3 \not\geq p$ , let  $y'_4 = y_3 \vee p$ . Then  $x \not\leq y'_4$  and  $x \wedge y'_4 = p$ . So we can assume  $y_4 \geq p$  and hence  $x \wedge y_4 = p$ . Note that  $x \vee y_4 < p \vee k$ , or else  $\text{SD}_\vee$  would yield  $x \vee y_4 = p \vee k = p \vee (x \wedge k) \vee (y_4 \wedge k)$ , while no two of these elements join to the top.

The following arguments apply when  $y_0 < k$ . Note that  $k \wedge (x \vee y_4) \leq y_4$ , or else  $x, y_4, k \wedge (x \vee y_4)$  is a 3 element antichain. Likewise  $k \wedge (x \vee y_4) \leq p \vee y_0$ , or else  $x, p \vee y_0, k \wedge (x \vee y_4)$  is a 3 element antichain. Also, using breadth 2,  $x \wedge k = x \wedge y_4 \wedge k \leq p$ .

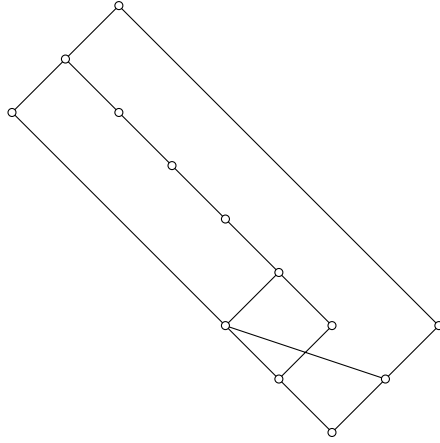
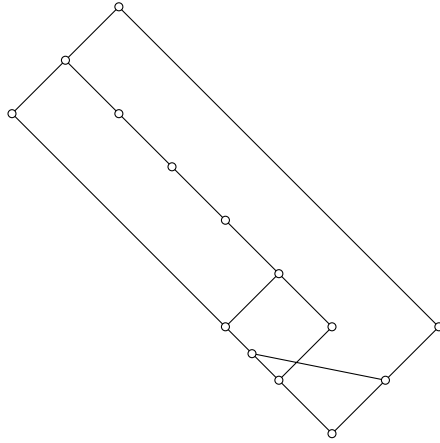
FIGURE 105.  $\mathbf{G}_{78}$ FIGURE 106.  $\mathbf{G}_{79}$ 

**Subcase 1.** If  $y_3 < k$ , then check that  $\{p \wedge k, y_0, y_1, y_2, k \wedge (x \vee y_0), k, p, p \vee y_0, x, x \vee y_0, p \vee k\}$  forms a sublattice of  $\mathbf{L}$  isomorphic to  $\mathbf{G}_{70}$ .

Thus we may assume that  $y_3 > p$ , and w.l.o.g.  $x \vee y_3 \geq y_4$ . Moreover,  $x \vee y_0 \geq y_3$ , or else Lemma 67 applies to the elements  $x, x \vee y_0, y_3, y_4$ . It follows that  $x \vee y_0 \geq y_4$ .

**Subcase 2.** If  $y_2 < k$ , then  $\{p \wedge k, y_0, y_1, k \wedge (x \vee y_0), k, p, p \vee y_0, y_4, x, x \vee y_0, p \vee k\}$  forms a sublattice of  $\mathbf{L}$  isomorphic to  $\mathbf{G}_{71}$ .

**Subcase 3.** If  $y_2 > p$  and  $y_1 < k$ , then  $\{p \wedge k, y_0, k \wedge (x \vee y_0), k, p, p \vee y_0, y_3, y_4, x, x \vee y_0, p \vee k\}$  forms a sublattice of  $\mathbf{L}$  isomorphic to  $\mathbf{G}_{72}$ .

**Subcase 4.** If  $y_1 > p$  and  $y_0 < k$ , then  $\{p \wedge k, k \wedge (x \vee y_0), k, p, p \vee y_0, y_2, y_3, y_4, x, x \vee y_0, p \vee k\}$  forms a sublattice of  $\mathbf{L}$  isomorphic to  $\mathbf{G}_{73}$ . (This lattice appeared earlier, but properly belongs here.)

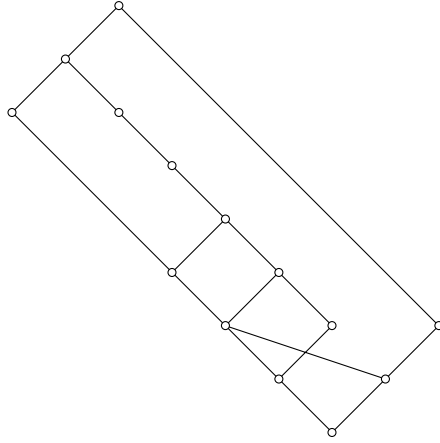
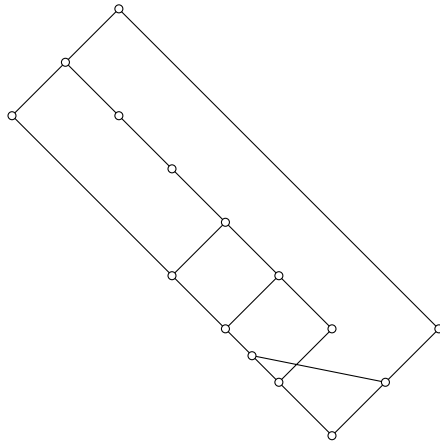
FIGURE 107.  $\mathbf{G}_{80}$ FIGURE 108.  $\mathbf{G}_{81}$ 

**Subcase 5.** Suppose  $y_0 > p$ . Note that we still have  $x \vee y_0 \geq y_4$  as above.

If  $x \wedge k \not\leq y_4$ , then Lemma 66 applies with the elements  $y_0, y_4, x$ . Hence we may assume  $x \wedge k \leq y_4$ , whence  $0 = p \wedge k = x \wedge y_4 \wedge k = x \wedge k$ .

Suppose  $y_4 \wedge k > 0$ . Then  $y_4 \wedge k \not\leq x$ , but  $y_4 \wedge k \leq y_0$  or else  $x, y_0, y_4 \wedge k$  is a 3 element antichain. Then replacing  $y_0$  by  $y_4 \wedge k$ , we can apply Subcase 4. Thus we may assume  $y_4 \wedge k = 0$ . By  $SD_{\wedge}$ , we get  $(x \vee y_4) \wedge k = 0$ .

Now check that  $\{0, k, p, y_0, y_1, y_2, y_3, y_4, x, x \vee y_0, p \vee k\}$  is a sublattice of  $\mathbf{L}$  isomorphic to  $\mathbf{G}_{74}$ .  $\square$

The second case covers  $F3=F1$ .

**Lemma 77.** *Let  $\mathbf{L}$  be a finite, semidistributive, breadth 2 lattice which contains incomparable elements  $p$  and  $k$ . Assume there exist  $x, y_0 < y_1 < y_2 < y_3 < y_4 \in p \vee k/p \cup k/p \wedge k$  such that*

1.  $p < x < p \vee k$ ,
2.  $y_0 \not\leq x$ ,
3.  $x \not\leq y_4$ ,
4.  $y_3 > p$  implies  $y_4 \wedge (x \vee y_3) > y_3$ ,
5.  $y_1 < k$  implies  $y_0 \vee (x \wedge y_1) < y_1$ ,
6.  $(x \wedge k) \vee (y_0 \wedge k) = k$ .

*Then the dual of Lemma 76 applies with  $x$  replaced by  $x \wedge k$ .*

*Proof.* If (6) holds, then  $p \vee k = p \vee (x \wedge k) \vee (y_0 \wedge k) = p \vee (y_0 \wedge k)$ , using the breadth 2 property. It follows that  $y_4 \not\leq p$ , and hence  $y_4 \leq k$ . It is straightforward to check that the hypotheses of the dual of Lemma 76 are satisfied.  $\square$

Next we consider C1 (which is implied by C3).

**Lemma 78.** *Let  $\mathbf{L}$  be a finite, semidistributive, breadth 2 lattice which contains incomparable elements  $p$  and  $k$ . Assume there exist  $x, y_0 < y_1 < y_2 < y_3 < y_4 \in p \vee k/p \cup k/p \wedge k$  such that*

1.  $p < x < p \vee k$ ,
2.  $y_0 \not\leq x$ ,
3.  $x \not\leq y_4$ ,
4.  $y_3 > p$  implies  $y_4 \wedge (x \vee y_3) > y_3$ ,
5.  $y_1 < k$  implies  $y_0 \vee (x \wedge y_1) < y_1$ ,
6.  $y_4 > p$  and  $y_4 \wedge x \leq y_3$ .

*Then  $\mathbf{L}$  contains a sublattice isomorphic to one of  $\mathbf{G}_{75}$ ,  $\mathbf{G}_{76}$ ,  $\mathbf{G}_{77}$ ,  $\mathbf{G}_{78}$ ,  $\mathbf{G}_{79}$ ,  $\mathbf{G}_{80}$ , or  $\mathbf{G}_{81}$ , or one of the previous lattices, and  $\mathbf{FQ}(p, k)$  is infinite. Thus  $\mathbf{L}$  is big.*

*Proof.* It follows from (6) that  $y_3 > p$ , and w.l.o.g. we may assume  $x \vee y_3 \geq y_4$ . As in Lemma 76,  $x \vee y_4 < p \vee k$ .

Suppose  $y_1 < k$ , in which case we may also assume  $x \wedge y_1 \leq y_0$ . If  $x \wedge k \not\leq y_1$ , then the dual of Lemma 66 applies to the elements  $y_1, y_0, x \wedge k$ . Thus we may assume  $x \wedge k \leq y_1$ , whence  $x \wedge k \leq x \wedge y_1 \leq y_0$ . Then condition E3 fails, in which condition C3 holds, or we reduce to a previous case. So  $y_4 \wedge x \leq y_2$  and  $y_2 > p$ . It is straightforward to check that Lemma 76 applies with  $p' = x \wedge y_4$ .

Next suppose  $y_1 > p$  and  $y_0 < k$ . Then condition E3 fails, so we may assume that condition C3 holds:  $y_4 \wedge x \leq y_2$ . We may assume that  $(x \vee y_4) \wedge k \leq y_1$ , or else  $x, y_1, (x \vee y_4) \wedge k$  forms a 3 element antichain. So replace  $y_0$  by  $y'_0 = (x \vee y_4) \wedge k$ . Further, we may assume that  $y_3 \leq x \vee y_0$ , and hence  $y_4 \leq x \vee y_0$ , or else Lemma 67 applies to the elements  $x, x \vee y_0, y_3, y_4$ .

If  $x \wedge y_4 \leq y_1$ , then Lemma 76 applies with  $p' = x \wedge y_4$ . But if  $x \wedge y_4 \not\leq y_1$ , then  $\{x \wedge k, y_0, k, x \wedge y_1, y_0 \vee (x \wedge y_1), x \wedge y_4, y_0 \vee (x \wedge y_4), y_3, y_4, x, x \vee y_0, p \vee k\}$  forms a sublattice of  $\mathbf{L}$  isomorphic to  $\mathbf{G}_{75}$ .

This leaves the case  $y_0 > p$ . Again condition C3 should hold, so that  $y_4 \wedge x \leq y_2$ . As above, we may assume that  $y_3 \leq x \vee y_0$ , and hence  $y_4 \leq x \vee y_0$ . Likewise, we may assume that  $x \wedge k \leq y_1$ , or else Lemma 66 applies to the elements  $y_0, y_1, x$ .

Now assume  $x \wedge k \leq y_0$ . Then  $(x \vee y_4) \wedge k \leq y_0$ , or else  $x, y_0, (x \vee y_4) \wedge k$  forms a 3 element antichain. However, if  $x \wedge y_1 \leq y_0$ , then the dual of Lemma 76 applies with  $p' = x \vee y_0, y'_i = y_{4-i}, x' = x$  and  $k' = k$ . So we may assume that  $x \wedge y_1 \not\leq y_0$ .

If  $x \wedge y_2 \leq y_1$ , then  $\{x \wedge k, k, x \wedge y_0, y_0, x \wedge y_1, y_0 \vee (x \wedge y_1), y_2, y_3, y_4, x, x \vee y_0, p \vee k\}$  forms a sublattice of  $\mathbf{L}$  isomorphic to  $\mathbf{G}_{76}$ . But if  $x \wedge y_2 \not\leq y_1$ , then  $\{x \wedge k, k, x \wedge y_0, y_0, x \wedge y_1, y_0 \vee (x \wedge y_1), x \wedge y_2, y_0 \vee (x \wedge y_2), y_3, y_4, x, x \vee y_0, p \vee k\}$  forms a sublattice of  $\mathbf{L}$  isomorphic to  $\mathbf{G}_{77}$ .

Finally, assume  $x \wedge k \not\leq y_0$  (but still  $x \wedge k \leq y_1$  from above). Then  $(x \vee y_4) \wedge k \leq x$ , or else  $x, y_0, (x \vee y_4) \wedge k$  forms a 3 element antichain. Note that  $x \wedge y_0 \wedge k = y_0 \wedge k$  by the breadth 2 property.

If perchance  $x \wedge y_1 \not\leq y_0 \vee (x \wedge k)$ , so that  $y_0 \vee (x \wedge y_1) > y_0 \vee (x \wedge k)$ , then the preceding argument applies with  $y'_0 = y_0 \vee (x \wedge k)$ . So we may assume that  $x \wedge y_1 \leq y_0 \vee (x \wedge k)$ .

Now check that if  $x \wedge y_2 \leq y_1$ , then  $\{y_0 \wedge k, x \wedge k, k, x \wedge y_0, y_0, (x \wedge y_0) \vee (x \wedge k), x \wedge y_1, y_0 \vee (x \wedge y_1), y_2, y_3, y_4, x, x \vee y_0, p \vee k\}$  forms a sublattice of  $\mathbf{L}$  isomorphic to either  $\mathbf{G}_{78}$  or  $\mathbf{G}_{79}$ , depending on whether or not  $(x \wedge y_0) \vee (x \wedge k) = x \wedge y_1$ . But if  $x \wedge y_2 \not\leq y_1$ , then  $\{y_0 \wedge k, x \wedge k, k, x \wedge y_0, y_0, (x \wedge y_0) \vee (x \wedge k), x \wedge y_1, y_0 \vee (x \wedge y_1), x \wedge y_2, y_0 \vee (x \wedge y_2), y_3, y_4, x, x \vee y_0, p \vee k\}$  forms a sublattice of  $\mathbf{L}$  isomorphic to either  $\mathbf{G}_{80}$  or  $\mathbf{G}_{81}$ , depending on whether or not  $(x \wedge y_0) \vee (x \wedge k) = x \wedge y_1$ .  $\square$

It follows that condition E1 (which implies E3) must hold:  $y_0 < k$  and  $y_0 \vee (x \wedge k) \geq y_2$ . But then the dual of Lemma 66 applies to the elements  $y_1, y_0, x \wedge k$ . This completes the proof of the theorem.

## 19. BIG MODULAR LATTICES

Now we turn our attention to modular lattices. Let  $\mathbf{S}$  be the lattice in Figure 109.

**Theorem 79.** *There is an infinite modular lattice  $\mathbf{M}$  such that  $\mathbf{S}$  is a maximal sublattice of  $\mathbf{M}$ .*

*Proof.* Just as  $\mathbf{S}$  is made by gluing four diamonds together, so we shall construct  $\mathbf{M}$  by gluing four lattices (with a twist).

Let  $\mathbf{Z}$  denote the integers, and let  $\mathbf{Z}^*$  be the lattice  $\mathbf{1} + \mathbf{Z} + \mathbf{1}$  obtained by adding a least and greatest element to  $\mathbf{Z}$ . Let  $\mathbf{F}$  be the lattice of all nondecreasing functions  $f : \mathbf{Z} \rightarrow \mathbf{M}_3$ , ordered pointwise. If  $\bar{0}, \bar{1}, \bar{a}, \bar{b}, \bar{c}$  denote the constant functions, then these elements form a sublattice  $\bar{\mathbf{M}}_3$  of  $\mathbf{F}$  isomorphic to  $\mathbf{M}_3$ . Each interval  $\bar{a}/\bar{0}, \bar{b}/\bar{0}, \bar{c}/\bar{0}, \bar{1}/\bar{a}, \bar{1}/\bar{b}, \bar{1}/\bar{c}$  is isomorphic to  $\mathbf{Z}^*$ . Moreover,  $\mathbf{F}$  is generated by  $\bar{\mathbf{M}}_3$  and the elements in any one of these legs, e.g.,  $\bar{\mathbf{M}}_3 \cup \bar{a}/\bar{0}$ .



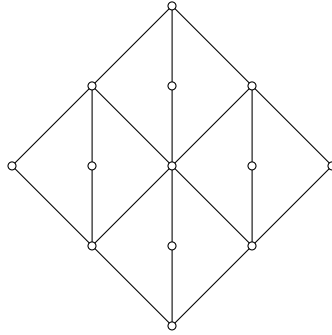

FIGURE 109.

To describe the gluing, we need to establish some notation. For  $u \prec v$  in  $\mathbf{M}_3$ , let  $f_{uiv}$  be the element of  $\overline{\mathbf{M}}_3$  such that

$$f_{uiv}(j) = \begin{cases} u & \text{if } j < i, \\ v & \text{if } j \geq i. \end{cases}$$

These are, of course, the elements of  $\mathbf{F}$  in the legs of  $\overline{\mathbf{M}}_3$ .

Let  $\mathbf{F}^B, \mathbf{F}^L, \mathbf{F}^R, \mathbf{F}^T$  be four (originally) disjoint copies of  $\mathbf{F}$ . We think of  $B, L, R, T$  as forming a lattice isomorphic to  $\mathbf{2} \times \mathbf{2}$  with  $B \leq L, R \leq T$ . All gluings described below are (tight) Hall-Dilworth gluings, and so preserve modularity. Our gluing scheme is indicated in Figure 110.

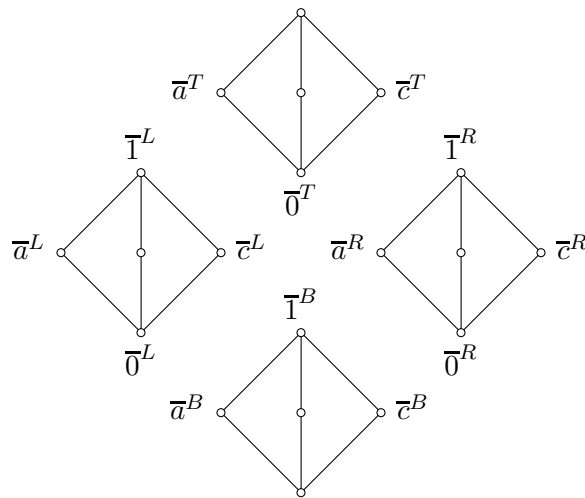

FIGURE 110.

Glue  $\mathbf{F}^R$  to  $\mathbf{F}^T$  by identifying  $\bar{\Gamma}^R/\bar{a}^R$  with  $\bar{c}^T/\bar{0}^T$  directly:  $\bar{\Gamma}^R \equiv \bar{c}^T$ ,  $\bar{a}^R \equiv \bar{0}^T$ , and  $f_{ai1}^R \equiv f_{0ic}^T$ . Also, glue  $\mathbf{F}^B$  to  $\mathbf{F}^L$  by identifying  $\bar{\Gamma}^B/\bar{a}^B$  with  $\bar{c}^L/\bar{0}^L$ , but this time with a shift:  $\bar{\Gamma}^B \equiv \bar{c}^L$ ,  $\bar{a}^B \equiv \bar{0}^L$ , and  $f_{ai1}^B \equiv f_{0(i+1)c}^L$ .

**Lemma 80.** *In the glued lattice  $\mathbf{F}^R \cup \mathbf{F}^T$ ,*

$$\bar{a}^T/\bar{0}^R = \bar{a}^T/\bar{0}^T \cup \bar{a}^R/\bar{0}^R \cong \mathbf{1} + \mathbf{Z} + \mathbf{1} + \mathbf{Z} + \mathbf{1}.$$

*Similarly, in the glued lattice  $\mathbf{F}^B \cup \mathbf{F}^L$ ,*

$$\bar{\Gamma}^L/\bar{c}^B = \bar{\Gamma}^L/\bar{c}^L \cup \bar{\Gamma}^B/\bar{c}^B \cong \mathbf{1} + \mathbf{Z} + \mathbf{1} + \mathbf{Z} + \mathbf{1}.$$

So we can glue these two parts together (directly, no shift) using another Hall-Dilworth gluing. If we call the resulting lattice  $\mathbf{M}$ , then  $\mathbf{S}$  is a maximal sublattice of  $\mathbf{M}$ . For if  $x$  is any element of  $\mathbf{M} - \mathbf{S}$ , then the sublattice generated by  $\mathbf{S} \cup \{x\}$  contains a point in one of the legs of one of the  $\mathbf{F}$ 's. Since each  $f_{uiv}^X$  projects around to  $f_{u(i+1)v}^X$  using only elements of  $\mathbf{S}$ , the entire leg is contained in the sublattice generated by  $\mathbf{S} \cup \{x\}$ . Finally, it is easy to see that any leg together with  $\mathbf{S}$  generates  $\mathbf{M}$ .  $\square$

The preceding construction must be modified somewhat to show that  $\mathbf{S}$  is a maximal sublattice of arbitrarily large finite lattices.

**Theorem 81.** *There are arbitrarily large finite modular lattices  $\mathbf{M}$  such that  $\mathbf{S}$  is a maximal sublattice of  $\mathbf{M}$ .*

*Proof.* For each positive integer  $n$ , let  $\mathbf{G}_n = \mathbf{M}_3^n$ . Again the constant functions  $\bar{0}, \bar{1}, \bar{a}, \bar{b}, \bar{c}$  form a sublattice  $\bar{\mathbf{M}}_3$  of  $\mathbf{G}_n$  isomorphic to  $\mathbf{M}_3$ . Each interval  $\bar{a}/\bar{0}, \bar{b}/\bar{0}, \bar{c}/\bar{0}, \bar{1}/\bar{a}, \bar{1}/\bar{b}, \bar{1}/\bar{c}$  is isomorphic to  $\mathbf{2}^n$ . Moreover,  $\mathbf{G}_n$  is generated by  $\bar{\mathbf{M}}_3$  and the elements in any one of these legs, e.g.,  $\bar{\mathbf{M}}_3 \cup \bar{a}/\bar{0}$ .

We need more. Let  $\pi : n \rightarrow n$  by  $\pi(i) = i + 1 \pmod n$ , and note that  $\pi$  induces natural automorphisms on  $\mathbf{G}_n = \mathbf{M}_3^n$  and  $\mathbf{2}^n$ , with  $(\pi(x))_i = x_{i+1}$ .

**Lemma 82.** *Assume  $n$  is prime. If  $\emptyset \subset A \subset n$ , then  $A, \pi A, \dots, \pi^{n-1}A$  generate  $\mathbf{2}^n$ .*

*Proof.* The proof is by induction on  $|A|$ . If  $|A| = 1$ , then  $A, \pi A, \dots, \pi^{n-1}A$  are the atoms of  $\mathbf{2}^n$ .

So let  $|A| > 1$ . Note that  $\bigcup \pi^k A = n$  as  $\{i, \dots, \pi^{n-1}(i)\} = n$ . If any pair  $\pi^i A, \pi^j A$  are distinct and not disjoint, then  $0 < |\pi^i A \cap \pi^j A| < |A|$ , and  $\pi^i A \cap \pi^j A$  is in the sublattice generated by  $A, \pi A, \dots, \pi^{n-1}A$ . But then so are all the sets  $\pi^k(\pi^i A \cap \pi^j A) = \pi^{i+k} A \cap \pi^{j+k} A$  for  $0 \leq k < n$  (since  $\pi$  is a permutation), and these generate  $\mathbf{2}^n$  by induction.

But if distinct sets  $\pi^i A$  are always disjoint, then they form a partition of  $n$  with equal sized blocks, which is impossible for  $n$  prime.  $\square$

So let  $n$  be prime, and let  $\mathbf{G}_n^B, \mathbf{G}_n^L, \mathbf{G}_n^R, \mathbf{G}_n^T$  be four (originally) disjoint copies of  $\mathbf{G}_n$ . Again we use (tight) Hall-Dilworth gluings, and so preserve modularity.

Glue  $\mathbf{G}_n^R$  to  $\mathbf{G}_n^T$  by identifying  $\bar{1}^R/\bar{a}^R$  with  $\bar{c}^T/\bar{0}^T$  directly, and glue  $\mathbf{G}_n^B$  to  $\mathbf{G}_n^L$  by identifying  $\bar{1}^B/\bar{a}^B$  with  $\bar{c}^L/\bar{0}^L$  using the shift induced by  $\pi$ , so that  $A^B \equiv \pi A^L$  for all  $A \subseteq n$ . Then, after checking that the quotients  $\bar{a}^T/\bar{0}^R$  and  $\bar{1}^L/\bar{c}^B$  are isomorphic, glue these two parts together with no shift to form  $\mathbf{M}$ .

The proof that this works is a straightforward modification of the previous argument. If  $x$  is any element of  $\mathbf{M} - \mathbf{S}$ , then the sublattice generated by  $\mathbf{S} \cup \{x\}$  contains a point in one of the legs of one of the  $\mathbf{G}_n$ 's, corresponding to a set  $A \subseteq n$ . This we can project around to obtain the sets corresponding to  $\pi^k A$  for  $0 \leq k < n$ . By Lemma 82, these generated the entire leg. Finally, any leg together with  $\mathbf{S}$  generates  $\mathbf{M}$ .  $\square$

For a field  $F$ , let  $\mathbf{S}_k(F)$  denote the subspace lattice of the vector space  $F^k$ . Then as the only subfield of  $\text{GF}(2^p)$  for  $p$  prime is  $Z_2$ , the Fano plane  $\mathbf{S}_3(Z_2)$  is a maximal sublattice of  $\mathbf{S}_3(\text{GF}(2^p))$ . The following conjecture is tempting.

**Conjecture.** *The Fano plane  $\mathbf{S}_3(Z_2)$  is not maximal in any infinite Arguesian (modular?) lattice.*

## 20. BIG ALGEBRAS IN OTHER VARIETIES

Let  $\mathcal{V}$  be a variety of algebras, and let  $\mathbf{A}$  be a finite algebra in  $\mathcal{V}$ . We say that  $\mathbf{A}$  is

1.  $\mathcal{V}$ -big if there exists an infinite  $\mathbf{B} \in \mathcal{V}$  with  $\mathbf{A} \prec \mathbf{B}$ ,
2.  $\mathcal{V}$ -small if  $\mathbf{A}$  is not  $\mathcal{V}$ -big, i.e.,  $\mathbf{A} \prec \mathbf{B} \in \mathcal{V}$  implies  $|\mathbf{B}| < \infty$ .
3.  $\mathcal{V}$ -strictly small if there is a finite bound on  $|\mathbf{B}|$  for algebras  $\mathbf{B} \in \mathcal{V}$  with  $\mathbf{A} \prec \mathbf{B}$ ,
4.  $\mathcal{V}$ -sortabig if  $\mathbf{A} \prec \mathbf{B}$  for arbitrarily large finite algebras  $\mathbf{B} \in \mathcal{V}$ .

First we note two extremes.

A. If  $\mathcal{V}$  is locally finite, then every finite algebra of  $\mathcal{V}$  is  $\mathcal{V}$ -strictly small.

B. If  $\mathcal{V}_\tau$  is the variety of all algebras of type  $\tau$ , then every finite algebra of  $\mathcal{V}_\tau$  is  $\mathcal{V}_\tau$ -sortabig. If  $\tau$  contains at least two operations of arity  $\geq 1$ , or at least one operation of arity  $\geq 2$ , then every finite algebra of  $\mathcal{V}$  is  $\mathcal{V}$ -big. (This is an easy exercise due to B. Jónsson.)

**Groups.** Let  $\mathbf{C}_p$  denote the cyclic group of order  $p$ . Considering  $\mathbf{G} \times \mathbf{C}_p$  for large primes  $p$ , we see that any finite group is  $\mathcal{G}$ -sortabig.

We claim that the two-element group  $\mathbf{C}_2$  is  $\mathcal{G}$ -small. Let  $C_2 = \{1, x\}$ , and suppose  $\mathbf{C}_2 \prec \mathbf{G}$ . If  $\mathbf{C}_2 \leq Z(\mathbf{G})$ , then it is easy to see that  $\mathbf{G}$  is finite. So w.l.o.g.  $\mathbf{G} = \text{Sg}(x, y)$  where  $y$  is a conjugate of  $x$ . It follows that  $\mathbf{G}$  is a dihedral group generated by  $x, xy$ . Then it must be of order  $2p$  with  $p$  prime for  $\text{Sg}(x)$  to be maximal. Thus  $\mathbf{G}$  is finite.

On the other hand, let  $\mathcal{B}_p$  denote the variety of groups of exponent  $p$ .

A. Ju. Ol'shanskii has shown that for every prime  $p > 10^{75}$ , there exists an infinite simple  $p$ -group all of whose proper subgroups are of order  $p$  [11].

Such a group has  $\mathbf{Sub}(\mathbf{G}) \cong \mathbf{M}_\omega$ . Thus for large primes  $\mathbf{C}_p$  is  $\mathcal{B}_p$ -big. However, by the solution of the restricted Burnside problem (Kostrikin [8], Zel'manov [15], [16]) no finite group in  $\mathcal{B}_p$  is  $\mathcal{B}_p$ -sortabig.

**Lattice varieties of finite height.** Similarly, let  $\mathcal{V}$  be a lattice variety such that

1.  $\mathcal{V}$  contains only finitely many finite subdirectly irreducibles (and at least one infinite one),
2. there is a finite lattice  $\mathbf{F} \in \mathcal{V}$  which is a maximal sublattice of an infinite lattice  $\mathbf{L} \in \mathcal{V}$ .

Such a variety was constructed in [10], and similar constructions yield other varieties with these properties. If  $\mathbf{F}$  is a maximal sublattice of a finite lattice  $\mathbf{K} \in \mathcal{V}$ , then  $|\mathbf{K}|$  is at most the cardinality of the relatively free lattice with  $|F| + 1$  generators in the variety generated by the finite members of  $\mathcal{V}$ , which is finite. Thus  $\mathbf{F}$  is  $\mathcal{V}$ -big, but there is a bound on the size of the finite minimal  $\mathcal{V}$ -extensions of  $\mathbf{F}$ .

**Lattices.** The main part of the paper shows that a finite lattice is either  $\mathcal{L}$ -big or  $\mathcal{L}$ -strictly small.

**Modular lattices.**  $\mathbf{M}_3$  is  $\mathcal{M}$ -strictly small. The section on modular lattices shows that there is a finite modular lattice which is  $\mathcal{M}$ -sortabig and  $\mathcal{M}$ -big. Beyond that we don't know much.

**A  $\mathcal{V}$ -big sublattice of a  $\mathcal{V}$ -strictly small lattice.** Let  $\mathbf{K}$  be the lattice in the paper with  $\mathbf{M}_3 \prec \mathbf{K}$ . Note that  $\mathbf{K}$  has width 4. Let  $\mathcal{V} = \text{HSP}(\mathbf{M}_5, \mathbf{K})$ . So  $\mathcal{V}_{si} = \{\mathbf{M}_4, \mathbf{M}_5\} \cup \mathcal{V}(\mathbf{K})_{si}$ , and the latter lattices all have width at most 4 by Jónsson's Lemma.

Now  $\mathbf{M}_3$  is  $\mathcal{V}$ -big, but we claim that  $\mathbf{M}_5$  is  $\mathcal{V}$ -strictly small. Suppose  $\mathbf{M}_5 \leq \mathbf{T} \in \mathcal{V}$  with  $T = \text{Sg}(\mathbf{M}_5 \cup \{p\})$ . Writing  $\mathbf{T}$  as a subdirect product, we have  $\mathbf{T} \leq \prod \mathbf{T}_i$  with each  $\mathbf{T}_i \in \mathcal{V}_{si}$ . If  $w(\mathbf{T}_i) \leq 4$ , then the projection map  $\pi_i : \mathbf{T} \rightarrow \mathbf{T}_i$  collapses  $\mathbf{M}_5$ , and so  $\pi_i(\mathbf{T}) = \mathbf{T}_i$  is 2-generated. Therefore  $\mathbf{T}_i \in \mathcal{V}(\mathbf{M}_5)$  for all  $i$ , and  $|T|$  is bounded (by  $|\mathbf{F}_{\mathcal{V}(\mathbf{M}_5)}(6)|$  say).

## REFERENCES

- [1] M. E. Adams, R. Freese, J. B. Nation, and J. Schmid, *Maximal sublattices and Frattini sublattices of bounded lattices*, J. Austral. Math. Soc. Ser A, **63** (1997), 110–127.
- [2] P. Crawley and R. P. Dilworth, *Algebraic theory of lattices*, Prentice-Hall, Englewood Cliffs, New Jersey, 1973.
- [3] B. A. Davey and H. A. Priestley, *An introduction to lattices and order*, Cambridge University Press, Cambridge, 1989.
- [4] R. Freese, *Finitely presented lattices: canonical forms and the covering relation*, Trans. Amer. Math. Soc. **312** (1989), 841–860.
- [5] R. Freese, J. Ježek, and J. B. Nation, *Free Lattices*, Amer. Math. Soc., Providence, 1995, Mathematical Surveys and Monographs, vol. 42.
- [6] J. Ježek and V. Slavík, *Free lattices over join-trivial partial lattices*, Algebra Universalis **27** (1990), 10–31.

- [7] B. Jónsson and I. Rival, *Lattice varieties covering the smallest nonmodular variety*, Pacific J. Math. **82** (1979), 463–478.
- [8] A. I. Kostrikin, *The Burnside problem*, Izv. Akad. Nauk SSSR, Ser. Mat. **23** (1959), 3–34 [Russian].
- [9] J. B. Nation, *Some varieties of semidistributive lattices*, Algebra and Lattice Theory, Charleston 1984, Lecture Notes in Mathematics **1149** (1985), Springer-Verlag, New York-Berlin, 198–223.
- [10] J. B. Nation, *A counterexample to the finite height conjecture*, Order **13** (1996), no. 1, 1–9.
- [11] A. Ju. Ol’shanskii, *Groups of bounded period with subgroups of prime order*, Algebra i Logika **21** (1982), 553–618.
- [12] I. Rival, *Maximal sublattices of finite distributive lattices*, Proc. Amer. Math. Soc. **37** (1973), 417–420.
- [13] V. Slavík, *Finiteness of finitely presented lattices*, Lattice Theory and its Applications, Heldermann, Lemgo, 1995.
- [14] V. Slavík, *Lattices with finite  $W$ -covers*, Algebra Universalis **36** (1996), 286–315.
- [15] E. I. Zel’manov, *Solution of the restricted Burnside problem for groups of odd exponent*, Izv. Akad. Nauk SSSR, Ser. Mat. **54** (1990), 42–59 [Russian].
- [16] E. I. Zel’manov, *Solution of the restricted Burnside problem for 2-groups*, Mat. Sb. **182** (1991), 568–592 [Russian].

UNIVERSITY OF HAWAII, HONOLULU, HI 96822  
*E-mail address:* ralph@math.hawaii.edu

CHARLES UNIVERSITY, PRAGUE  
*E-mail address:* jezek@karlin.mff.cuni.cz

UNIVERSITY OF HAWAII, HONOLULU, HI 96822  
*E-mail address:* jb@math.hawaii.edu